



SCREW & BARREL INSPECTION ROLLERS

FOR FAST EASY INSPECTION OR CLEANING



Rotate the screw with one finger.

- HOLDS 1" TO 8" DIA.
- ALL STAINLESS STEEL BASE
- BALL BEARING ROLLERS (PERMANENTLY LUBRICATED)
- SOLID U SHAPED BASE WITH MOUNTING HOLES.
- 3 ADJUSTMENT SLOTS FIT VARIOUS DIAMETERS.

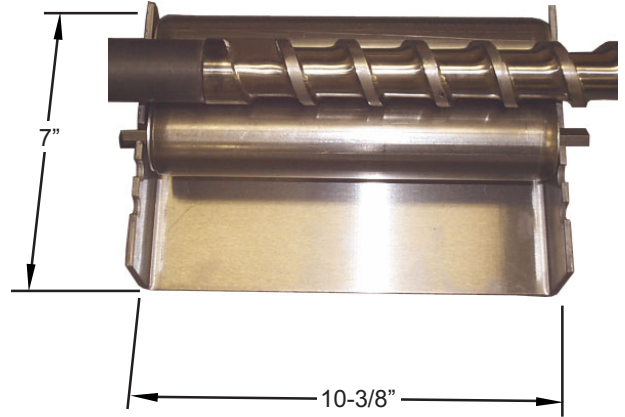

Kit contains:
1 - Base
2 - Rollers



PART NO.	DESCRIPTION	PRICE EACH
SHR4	Inspection Roller Kit (complete)	\$172.00
SHR4B	Stainless Steel Base	\$90.00
SHR4R	Ball Bearing Roller	\$41.00



SCREW HANDLER TOOL

FOR INSTALLING, REMOVING OR CARRYING SCREWS

**A SAFE, SIMPLE,
BUT EFFECTIVE WAY
TO TRANSPORT SCREWS**

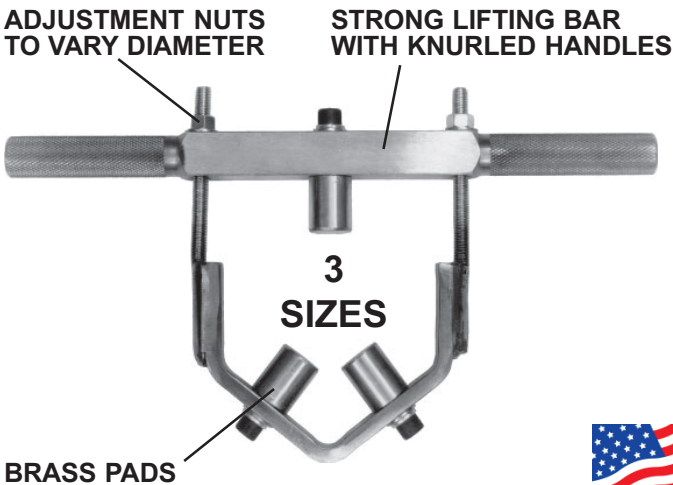

BRASS PADS CAN BE MODIFIED OR CHANGED TO SUIT YOUR APPLICATION



PART NO.	SCREW DIAMETER SIZE RANGE	PRICE EACH
SHT-1	5/8" TO 1 3/4" 15mm - 45mm	\$154.55 ea.
SHT-2	1 9/16" to 3 1/8" 40mm - 80mm	\$181.00 ea.
SHT-3	3" to 7" 75mm -177mm	\$198.00 ea.



PLASTIC PROCESS EQUIPMENT, INC.

8303 CORPORATE PARK DRIVE
MACEDONIA, OHIO 44056-2300
216-367-7000 • FAX: 216-367-7022
TOLL FREE: 800-321-0562

6385 MONTESSOURI STREET
LAS VEGAS, NEVADA 89113-1186
702-433-6385 • FAX: 702-433-6388
TOLL FREE: 800-258-8877

www.ppe.com
e-mail: sales@ppe.com

Toll Free: USA, Canada & Mexico
800-362-0706

Order Fax: 800-223-8305