



HEATER BAND ORDER FORM CONFIRMATION

1. QUANTITY: _____ 2. MACHINE MAKE AND TYPE: _____

3. TYPE OF HEATER:

- PREMIUM MICA
- EXPANDABLE MICA (4" dia. & over)
- MINERAL INSULATED BAND
- STARFLEX
- STANDARD CERAMIC (1/4" insulation)
- ULTRA THIN CERAMIC (3/16" insulation)
- INSULATION MAX[®] CERAMIC (1/2" insulation)

4. DESIGN OF HEATER: (see catalog) _____ i.e. wedge lock, flange lock, etc.

5. ELECTRICAL SPEC'S:

- Voltage: _____ Volts
 - Wattage: _____ Watts
 - Dual Voltage
- To determine heater wattage multiply 3.14 x I.D. x width.

7. HEATER CONSTRUCTION:

- Standard One Piece
- 2 Piece Construction (3" I.D. min. size)
Voltage each half: _____
- Hinged Construction
- Expandable
- Stainless Steel Inner Liner
- T/C or Clearance Holes (specify location)
Hole Diameter: _____
No. of Holes: _____

6. ELECTRICAL CONN: (Specify)

- Flex Leads Type C: Length (std 10 in.) _____ in.
- Metal Braid Type B: Length _____ in.
- Armor Conduit Type A: Length _____ in.
- Post Terminals 10-24 Thread (standard - Mica)
- Post Terminals 10-32 Thread
- Post Terminals 1/4-20 Thread (standard - Ceramic)
- Terminal Box
- Ceramic Terminal Covers
- Plug (Specify)
- Euro Style Plug: Vertical or Horizontal
- Twist Plug
- Grounding Provision
- 3 Phase

8. LOCKUP:

- Straps
- Flange
- Wedge Lock

SPECIAL LOCKUP:

- Full Width Strap
- Welded Barrel Nut

★★ EXPRESS DELIVERY FOR ★★ CUSTOM MADE HEATER BANDS

FOR EXPRESS EXTRA FAST DELIVERY ON PREMIUM HEATER BANDS
FOR SHIPPING IN 7 WORKING DAYS ADD 20% SURCHARGE.
FOR SHIPPING IN 5 WORKING DAYS ADD 30% SURCHARGE.
FOR SHIPPING IN 3 WORKING DAYS ADD 50% SURCHARGE.

NOTE: Indicate hole/s location on drawing below by indicating the appropriate angle and location on the side view.

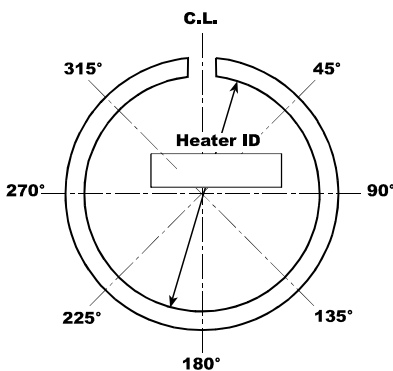

1 PIECE DESIGN

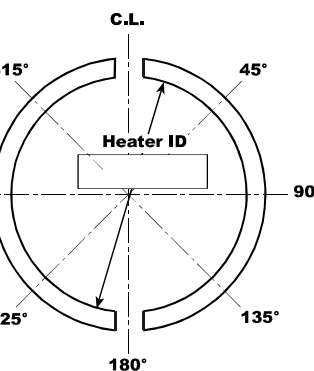
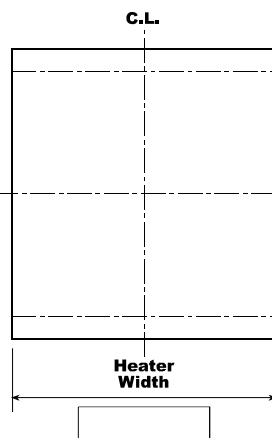

2 PIECE DESIGN

Possibility of over/under on quantities of special orders

PPE Mica & Ceramic

QTY. Ordered	Over/Under QTY.
1-5	No Variation
6-24	± 1pc
25-49	± 2pcs
50-99	± 3pcs
100+	± 5%

Mineral Insulated

QTY. Ordered	Over/Under QTY.
1-5	No Variation
6-24	± 1pc
25-49	± 2pcs
50-99	± 3pcs
100+	± 5%

COMPANY NAME: _____

YOUR NAME: _____ / SIGNATURE: _____

TELEPHONE: (_____) - _____ - _____ FAX: (_____) - _____ - _____

E-MAIL: _____ PPE SALES PERSON: _____

© Copyright 2023 Plastic Process Equipment, Inc. Note: PPE customers may reproduce this form only in it's entirety. QUOTE# _____



PLASTIC PROCESS EQUIPMENT, INC.

8303 CORPORATE PARK DRIVE
MACEDONIA, OHIO 44056-2300
216-367-7000 • FAX: 216-367-7022
TOLL FREE: 800-321-0562

6385 MONTESSOURI STREET
LAS VEGAS, NEVADA 89113-1186
702-433-6385 • FAX: 702-433-6388
TOLL FREE: 800-258-8877

www.ppe.com

e-mail: sales@ppe.com

Toll Free: USA, Canada & Mexico

800-362-0706

Order Fax: 800-223-8305