



# PNEUMATIC BOX TILTER

## FLOOR LEVEL LOADING - 2000 LBS CAPACITY



AIR OPERATED — AUTOMATIC TILTING



Made in USA



ADJUSTABLE  
PROBE HOLDER  
35" TO 57"

ADJUSTABLE  
BOX HOLDER  
30" TO 55"

**4 MODELS  
IN STOCK**

**BEST  
QUALITY  
& PRICES**

MODEL BT1600

**\$2,530.<sup>00</sup>**

**- FEATURES & SPECIFICATIONS -**

- Capacity - 2000 lbs.
- Strong laser cut 7 ga. steel.
- Automatic tilt pressure regulator adjusts air pressure to lifting weight ratio.
- Extra Heavy Duty Air Bag rated to 7200 lbs.
- No special stops needed.
- Powder coated paint for more durability .
- Size: 44" X 44", floor level loading for fast easy loading.
- Adjustable material pickup probe holder 35" to 57" above platform.
- Tilt angle - 48°.
- Pivot has a 1" sleeve bearing.
- Safety tilt stop (stops at 48°).
- Hand knob On-Off air control operator. Includes pressure regulator and gauge.
- Operating pressure rating 20 to 40 P.S.I.  
\*\*40 P.S.I will lift approximately 800 lbs. 3 in.
- Optional foot pedal operator and vibrator packages available, see table.
- Shipping weight, approximately 445 lbs.
- For safety & stability do not mount on casters!
- No spare parts required

**\*\*HOW A BOX TILTER FUNCTIONS**

Adjust pressure regulator to a specific setting based on the required lifting weight needed to tilt your box or drum. We suggest 40 psi operating pressure. A continuous pressure automatically lifts the container as it becomes lighter which will shift your material toward your vacuum tube. Tilting is smooth and positive with an air bag device. Air bag is rated to 7200 lbs.

PART NO.	DESCRIPTION	PRICE EACH
BT1600	Pneumatic Box Tilter w/Standard Controls	\$2,530.00
BT1600FP	Pneumatic Box Tilter w/Foot Pedal Operator	\$2,743.00
*BT1600VB	Pneumatic Box Tilter w/Vibrator	\$2,930.00
*BT1600FPVB	Pneumatic Box Tilter w/Foot Pedal & Vibrator	\$3,030.00

\* Vibrator models include an air line oiler to keep vibrator lubricated.

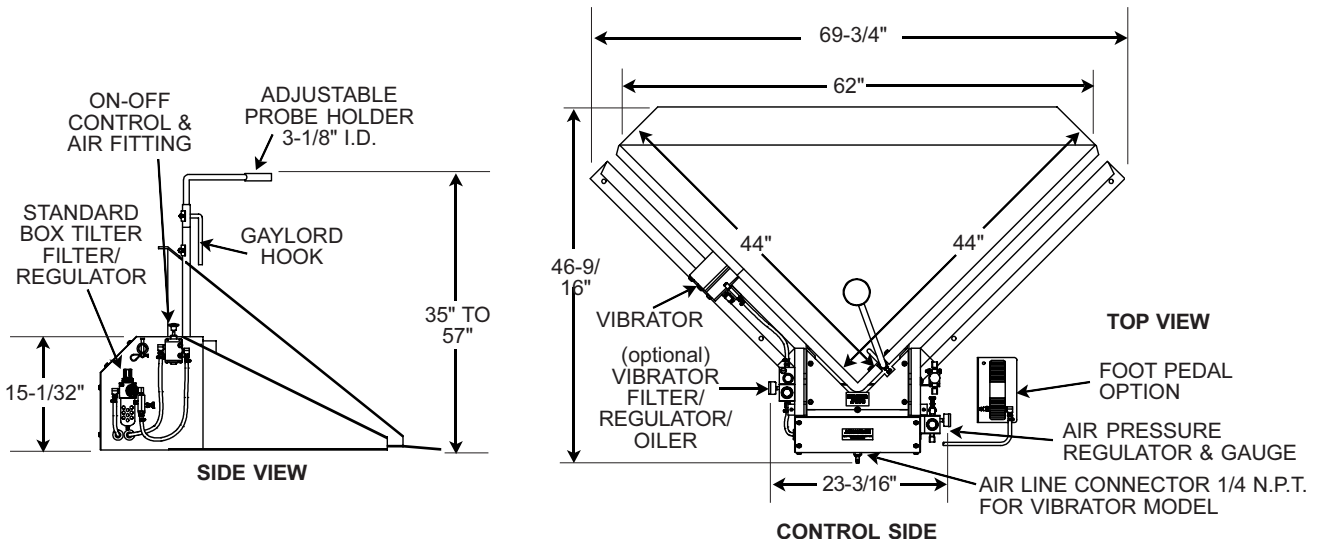

**PLASTIC PROCESS EQUIPMENT, INC.**

8303 CORPORATE PARK DRIVE  
MACEDONIA, OHIO 44056-2300  
216-367-7000 • FAX: 216-367-7022  
TOLL FREE: 800-321-0562

6385 MONTESSOURI STREET  
LAS VEGAS, NEVADA 89113-1186  
702-433-6385 • FAX: 702-433-6388  
TOLL FREE: 800-258-8877

[www.ppe.com](http://www.ppe.com)

e-mail: [sales@ppe.com](mailto:sales@ppe.com)

Toll Free: USA, Canada & Mexico

**800-362-0706**

Order Fax: 800-223-8305