



HOT MELT NOZZLE THERMOCOUPLE

FOR DIRECT TEMPERATURE READINGS OF THE HOT PLASTIC MELT INSIDE YOUR NOZZLE!

TYPE J
&
TYPE K

BOTH MODELS ARE REPLACEABLE AND INTERCHANGEABLE

STYLE F

THERMOCOUPLE JUNCTION IS FLUSH IN NOZZLE WALL

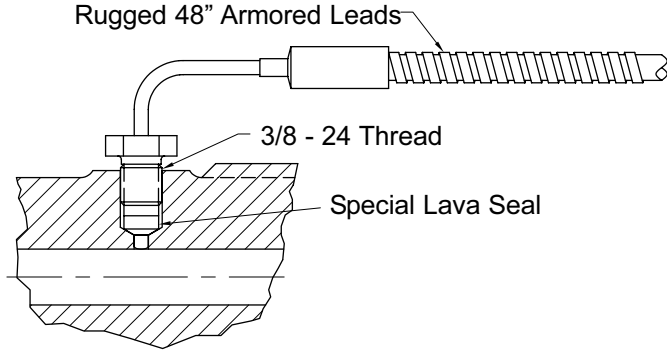

PPE STYLE F flush mount T.C. can be installed in most nozzles. The special wire junction mounts flush with the internal nozzle bore to avoid obstruction or damming the flow of plastic material. It is completely replaceable and does not require costly welding or factory replacement.

PRICES

STYLE F, TYPE J Thermocouple #HMTTC-F	\$17.35
STYLE F, TYPE K Thermocouple #HMTCK-F	\$20.05
Drilling and Tapping Nozzle	\$22.00
Spare Lava Seal Packing #HMTTC-S	\$3.25
Hot Melt T.C. Hole Plug #HMP3824 w/no lava seal	\$9.00
(Seals T.C. Hole when T.C. is removed)	

STYLE M

THERMOCOUPLE JUNCTION IS CENTERED IN HOT MELT STREAM

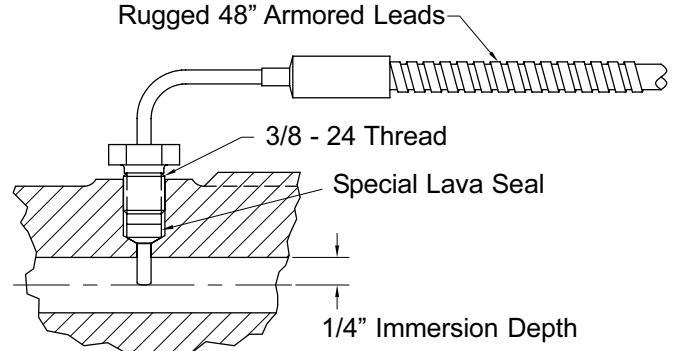

PPE STYLE M melt temperature sensing T.C. can be installed in most nozzles. The special sensing probe protrudes into the center of the hot melt stream for precise temperature readings. Some care must be exercised to avoid damaging the probe. Avoid cold starts or excessive molding pressure.

PRICES

STYLE M, TYPE J Thermocouple #HMTTC-M	\$18.75
STYLE M, TYPE K Thermocouple #HMTCK-M	\$18.85
Drilling and Tapping Nozzle	\$22.00
Spare Lava Seal Packing #HMTTC-S	\$3.25

GUIDE TO THERMOCOUPLE CONDUCTORS

A complete choice of ISA sensing ranges can be supplied depending on environment and read out equipment.

Non-standard ISA sensing ranges can be supplied on special order. In either case premium grade thermocouple wire is always used.

ISA Code	Conductor Characteristics				Temperature Range (°F)	Limits of Error		Application Notes
	Positive	Color	Negative	Color		Standard	Special	
J	Iron (Magnetic)	White	Constantan (Non-Magnetic)	Red	0 to 530	± 4°F	± 2°F	Reducing atmosphere recommend.
					530 to 1400	± 3/4%	± 3/8%	
T	Copper	Blue	Constantan (Silver Metal)	Red	-75 to 200	± 1-1/2°F	± 3/4°F	Can be used in oxidizing or reducing atmospheres: corrosion resistant.
					200 to 700	± 3/4%	± 3/8%	
K	Chromel (Non-Magnetic)	Yellow	Alumel (Magnetic)	Red	0 to 530	± 4°F	± 2°F	Oxidizing atmosphere recommended.
					530 to 2300	± 3/4%	± 3/8%	
E	Chromel	Purple	Constantan	Red	0 to 600	± 3°F	-	Oxidizing atmosphere recommended Highest emf output.
					600 to 1600	± 1/2%	± 3/8%	
S	Platinum 10% Rhodium	Black	Platinum	Red	0 to 1000	± 5°F	± 2-1/2°F	Oxidizing atmosphere recommended. Easily contaminated.
					1000 to 2700	± 1/2%	± 1/4%	
R	Platinum 13% Rhodium	Green	Platinum	Red	0 to 1200	± 5°F	± 2-1/2°F	Same conditions as 10% above but has slightly higher emf.
					1200 to 2700	± 1/2%	± 1/4%	
G (W)	Tungsten	White	Tungsten 25% Rhenium	Red	32 to 800	± 8°F	-	Needs protective atmosphere such as hydrogen, inert gas or vacuum.
					800 to 4200	± 1°F	-	
D (W3)	Tungsten 3% Rhenium		Tungsten 25% Rhenium		32 to 4350	± 2°F	-	Similar to Type W except greater ductility in positive leg.
C (W5)	Tungsten 5% Rhenium	White	Tungsten 26% Rhenium	Red	32 to 800	± 8°F	-	Higher mechanical strength than Type W Higher emf to 3400°F
					800 to 4100	± 1°F	-	
N	Nicrosil	Orange	Nisil	Red	32 to 2300	± 4°F	-	Alternative to Type K. Longer life and better stability than type K.



PLASTIC PROCESS EQUIPMENT, INC.

www.ppe.com • e-mail: sales@ppe.com

6385 Montessouri Street, Las Vegas, Nevada 89113
702-433-6385 • 800-258-8877 • Fax: 702-433-6388

11218 Challenger Avenue, Odessa, Florida 33556
727-834-8888 • 800-282-6783 • Fax: 727-834-8873

8303 CORPORATE PARK DRIVE, MACEDONIA (Cleveland), OHIO 44056, USA

Toll Free: USA, Canada & Mexico
800-362-0706

PPE 216-367-7000 • Toll Free: 800-321-0562 • Fax: 216-367-7022 • Order Fax: 800-223-8305