



INSTRUCTIONS CONVEYORS & SEPARATORS



Bottle & Parts



**Conveyor/Separator
Combination**



Inclined & Infeed Combo



**Vee-Guide
Tracking**



FIC Conveyor



Granulator Feed



Inclined



Parts Conveyor

MODEL NO.
<input type="text"/>
SERIAL NO.
<input type="text"/>

PPE Conveyors are manufactured and sold direct by Plastic Process Equipment, Inc. We are not associated with any other manufacturer except Budget Molder's Supply, Inc. Always specify genuine PPE or Budget Hi-Line conveyors! Do not accept substitutes.

Made in the U.S.A. by Plastic Process Equipment, Inc. © copyright 2006



PLASTIC PROCESS EQUIPMENT, INC.

www.ppe.com • e-mail: sales@ppe.com



6385 Montessouri Street, Las Vegas, Nevada 89113
702-433-6385 • 800-258-8877 • Fax: 702-433-6388



11218 Challenger Avenue, Odessa, Florida 33556
727-834-8888 • 800-282-6783 • Fax: 727-834-8873

8303 CORPORATE PARK DRIVE, MACEDONIA (Cleveland), OHIO 44056, USA

216-367-7000 • Toll Free: 800-321-0562 • Fax: 216-367-7022 • Order Fax: 800-223-8305

Toll Free: USA, Canada & Mexico
800-362-0706

Thank you for purchasing a conveyor or separator from Plastic Process Equipment, Inc. These instructions are intended as a guide for your new product. If you have any additional questions, contact PPE at 800-321-0562.

RECEIVING

Thoroughly inspect your new conveyor or separator before unpacking it for set up. Report any damage to the motor freight carrier; they are responsible for damages incurred during transit.

ATTENTION!!

Please read through the entire booklet first.

You must be trained and authorized by your employer in the proper installation operation, maintenance and set-up of your new equipment. **Safety First Always!**

ELECTRICAL

All conveyors and separators are equipped with a starter switch and an overload protection heater. A grounded 120 volt outlet and a three wire grounded extension cord must be used at all times.

The On/Off switches on some models are resettable, should the switch get overloaded for some reason it may be necessary to reset it before the conveyor will run again. See switch cover for reset instructions.

WARNING DRIVE MOTOR

The standard 1/6hp 655 drive motor is not designed for repeated start stop operation, if you turn the conveyor on and off more than 10 times per hour you damage the motor by overheating. There are special order motors available for start/stop operations, please consult the factory.

CAUTION DURING USE AND OPERATION OF CONVEYORS OR SEPARATORS

- Do not wear loose clothing or jewelry around the conveyor.
- Do not wear rings, necklaces, or jewelry.
- Long hair **must** be tied and netted.
- Keep all hands, arms, and fingers away from any moving parts except the conveyor belt surface.
- Never stand on the conveyor belt for any reason whatsoever.
- Do not operate any conveyor with the guards removed.
- Do not operate the conveyor with parts missing, removed, or in a disassembled state.
- Pay special attention to the ON-OFF switch location.
- Wear safety glasses if your company or process requires them.
- You must unplug the conveyor before performing any repairs or maintenance.
- If you are unsure about installation, operation, maintenance, or setup call PPE!

TYPES OF CONVEYORS

PPE carries both V-Belt and non V-Belt Conveyors. The easiest way to tell if your conveyor is a V-Belt is by the serial number. If there is a "V" in the serial number your conveyor is a V-Belt. **EXAMPLE:** the serial number PC1812V251439 is a conveyor with the V-Belt system (note the V in the serial number). If the serial number on your conveyor has an **R** or an **A** following the **V**, your conveyor has direct drive. **EXAMPLE:** PC 182VR251439 is a direct drive conveyor.

BELT TRACKING AND TENSION

All conveyors and separators are thoroughly tested in our factory after final assembly. Although the belts are adjusted to track properly with the right amount of tension, some adjustments may be necessary during use. For best results and longevity of the drive components, the belt should be run with the **LEAST** tension needed to transport the load without slipping. If the belt is too loose, it will slip causing wear to the belt's underside. **CAUTION: DO NOT OVERTIGHTEN THE CONVEYOR BELT.** An overtightened belt will cause premature failure of your bearings, shafts and, on some models, the drive unit.

BELT TRACKING: THE V-BELT STYLE

The V-Belt tracking system keeps your belt centered and tracking properly. No adjustment should be necessary if both take up bolts are adjusted the same amount during belt tension adjustment. To check the tracking of your belt, measure the take up bolts on both sides of the conveyor. The distance between the center of the roller shaft and the bracket behind the locking nut (**see Figure 1**) should be the same for both bolts.

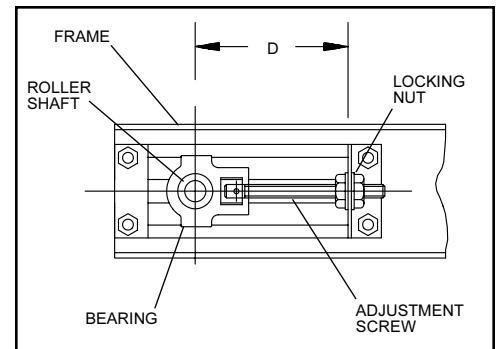

Figure 1

For another quick check, place a carpenter's square along the frame and belt of your conveyor. If it is tracking properly, the carpenter's square will fit snugly in the corner (see **Figure 2**). If your conveyor is not tracking properly, adjust

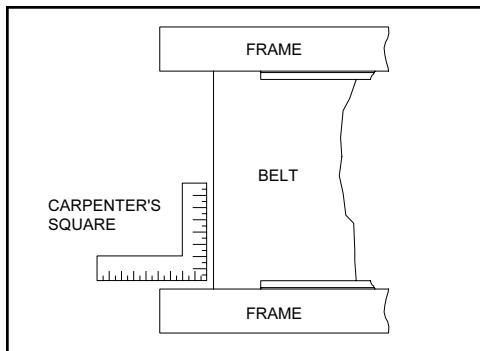

Figure 2

the locking nuts on both sides until they are equal. **BE CAREFUL NOT TO OVERTIGHTEN!**

BELT TRACKING: NON V-BELT CONVEYORS

Check to ensure your conveyor is tracking properly. If your belt drifts to the left or right, it needs adjustment. To adjust your belt, loosen the locking nuts on each side of the conveyor (see **Figure 1**). With the conveyor operating, tighten the tension screw on the side of the drift 1/4 turn (**EXAMPLE:** if your belt drifts to the right, tighten the right take-up screw approximately 1/4 turn). Wait several minutes to allow the belt to drift and reposition on the rollers. Continue to adjust the appropriate take up bolt until the belt tracks evenly on both sides. **DO NOT OVERTIGHTEN THE CONVEYOR BELT!** If necessary, reset the belt tracking by loosening the opposite side. Once the belt tracking is complete, be sure to lock the take up adjustment screws with the locking nut.

LUBRICATION: DIRECT DRIVE UNITS

PPE conveyors and separators (FIC, FT, ICB, PC-06, PC, PUC, SCI and FS Separator) have two drive bearings (the bearings at the motor end of the conveyor), and the take-up bearing (at the opposite end of the conveyor). All bearings are permanently lubricated, therefore we do not provide a grease fitting. Our experience has shown conveyor users tend to over grease bearings to the point where grease works its way between the rollers and belts causing serious problems of contamination and belt slippage.

LUBRICATION: CHAIN DRIVE UNITS

(BIC, FT, FS, VICB, PC 06, PC 12, PC 18, PC 24, PCS, PUC, VIB, ICG, PCS) PPE chain drive units use permanently lubricated drive chains that do not require lubrication. All bearings are permanently lubricated, therefore we do not provide a grease fitting.

CAUTION:
**DO NOT ALLOW LUBRICATION TO GET
ON THE UNDERSIDE OF THE BELT.**

CAUTION:
**BEARINGS SHOULD NOT RUN CONTINUOUS
AT TEMPERATURES OVER 200°F
AND SHOULD NEVER EXCEED 225°F
FOR INTERMITTENT OPERATIONS.**

PCS SEPARATOR ATTACHMENTS

The PCS separator is driven off of the main conveyor unit using a belt drive system. This allows slippage if the separator roller unit were to catch on something. **DO NOT OVERTIGHTEN** the drive belt, it should have just enough tension to drive the roller. This is a safety feature.

WARRANTY

All PPE Conveyors have a full **two year warranty**. This warranty doesn't include conveyor belts because they are subject to excessive wear damage and abuse by the user. This Warranty should not extend to goods subjected to misuse, abuse, neglect, accident or improper installation or maintenance, or products or goods which have been altered, modified or repaired by anyone other than seller or its authorized and approved representatives.

VUC CONVEYOR PARTS

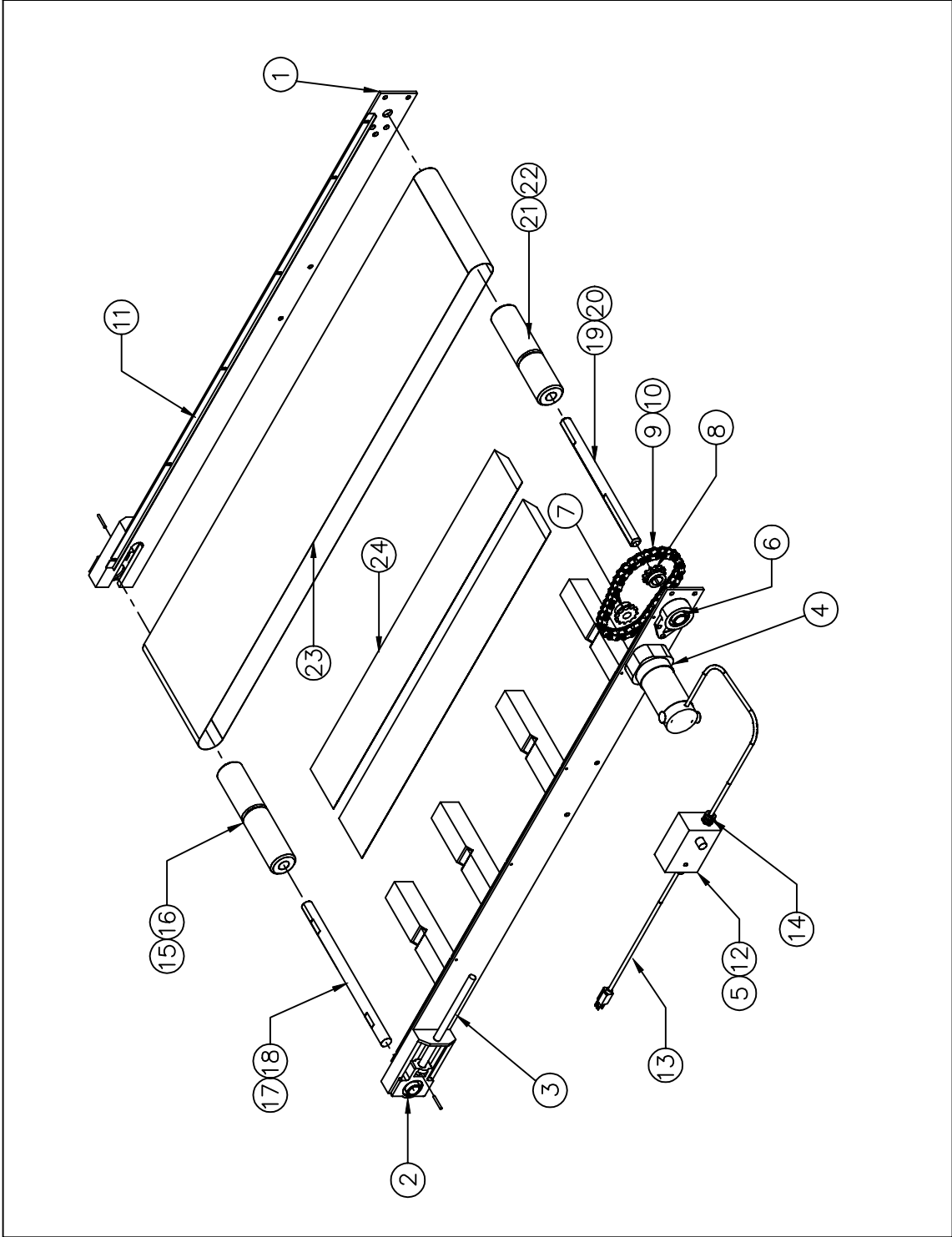

PLASTIC PROCESS EQUIPMENT, INC.

8303 Corporate Park Drive, Macedonia (CLEVELAND), OHIO 44056
(216) 367-7000 TOLL FREE: 800-321-0562 FAX (216) 367-7022 ORDER FAX: 800-223-8305 EMAIL: SALES@PPE.COM

6385 Montessori Street, Las Vegas, Nevada 89113
(702) 433-6385 TOLL FREE: 800-258-8877
FAX: (702) 433-6388

11218 Challenger Ave., Odessa, FL 33556
(727) 834-8888 TOLL FREE: 800-282-6783
FAX: (727) 834-8873

VUC CONVEYOR

09/17/15

ID	P/N	DESCRIPTION	UOM	
OPTIONAL	A-10855	ADJUSTABLE LEG FOR VUC (PAIR)	PAIR	
1	D-3174-W-L	FRAME	EA	
2	TU250X1	TAKE-UP BEARING	EA	
3	C-5582B	ADJ BOLT FOR TAKE UP BRACKET	EA	
4	1060	1/4 HP DC MOTOR	EA	
5	KB9380C	VARI SPEED CONTROL	EA	
6	FB16X1	FIXED BEARING	EA	
7	H40B12X5/8	4012 X 5/8 HARDENED SPROCKET	EA	
8	H40B12X1	4012 X 1" HARDENED SPROCKET DRIVEN	EA	
9	40CK	40 CHAIN, HALF LINK, MASTER LINK KIT	EA	
11	B-8190-93	BCP BELT STRIPS 93" (SET)	set	
12	FUSE	FUSE	EA	
13	K5152	K5152 12' POWER CORD	EA	
14	3201	3201 NON METALLIC CORD SAVERS	EA	
15	B-5578-12	VEE GROOVE ROLLER 12"	EA	
16	B-5578-18	VEE GROOVE ROLLER 18"	EA	
17	B-5620-12	IDLER SHAFT 12"	EA	
18	B-5620-18	IDLER SHAFT 18"	EA	
19	B-6819-12	1" DRIVE SHAFT PC BCP FT	EA	
20	B-6819-18	1" DRIVE SHAFT PC BCP FT	EA	
21	A-6821-12N	V-GR DR ROLLER 1" SHAFT PC/PCS BODINE	EA	
22	A-6821-18N	V-GR DR ROLLER 1" SHAFT PC/PCS BODINE	EA	
23	BELT	SEE BELT LIST	EA	
24	B-1285	BEDDING	EA	

SEE BELT SHEET FOR BELTS