

Series RMT Hot Runner Controller Setup and Operation Manual



Littlefuse® is a registered trademark of Littlefuse, Inc.

G® is a registered trademark of the DME Corporation.

SafeChange™ is a trademark of Athena Controls, Inc.

Precautions

Warning



Use of this equipment in a manner not specified by the manufacturer may impair protection provided by the equipment.

In addition to presenting a potential fire hazard, high voltage and high temperature can damage equipment and cause severe injury or death. When installing or using this instrument, follow all instructions carefully and use approved safety controls.

Hazardous potentials exist on components inside the mainframe and controller. Always disconnect AC power to the mainframe when servicing the controllers or the mainframe.

Because these temperature controls or associated equipment may not always fail safe, an approved temperature and/or pressure safety control should be used for safe operation.

The controller power switch must be in the “OFF” position before you put a controller into an energized mainframe, or remove a controller from an energized mainframe. If the mainframe supports the SafeChange™ feature, enable SafeChange on the controller to reduce the possibility of damage to the controller when installing or removing a controller from the mainframe. Controllers are shipped with the SafeChange feature disabled. To determine whether the mainframe supports SafeChange and to enable SafeChange, follow the instructions in Section 3.

Turn off power to the controller before cleaning the exterior of the controller.

Failure to observe these precautions can result in exposure to a potentially lethal shock hazard.

Changing jumper settings and all wiring should be done by an experienced technician. The controller and wiring should be installed in accordance with national and local electrical codes. To avoid serious personal injury and damage to equipment, follow all warnings and cautions provided in the manual supplied with the mainframe.

Caution



If a controller shows signs of having been damaged during shipping, do not power up or install the controller. Save all packing materials and report any damage to the carrier immediately.

When the controller is powered up, the output may be activated. Consider the effects on your process before powering up the controller.

Do not locate this instrument where it may be subjected to excessive shock, vibration, dirt, moisture, oil, or other liquids.

This is a Class A product. In domestic environment this product may cause radio interference, in which case the user may be required to take adequate measures.

Specified operating ambient temperature is 32 to 150 °F (0 to 65 °C).



Notes on CE EMC Compliance

This unit is compliant with the following standards when properly installed into a grounded metal housing. EMC testing was conducted with a load of 1 amp and setpoint of 400 °F.

- EMC directive (89/336/EEC)
- EN 50081-1 (1992 edition)
- EN 50082-1 (1992 edition)
- Low Voltage Directive (73/23/EEC)
- EN 61010-1 (1992 edition, Amendments 1, 2, 3, 4 and 11)



USE OF THIS EQUIPMENT IN A MANNER NOT SPECIFIED BY THE MANUFACTURER MAY IMPAIR PROTECTION PROVIDED BY THE EQUIPMENT!

UNIT	OUTPUT RATING (AMPS / VOLTS)	FUSE RATING (AMPS)	TYPE
RM SERIES	15 / 265	15	Fast-Acting 'F'

CLEANING INSTRUCTIONS

- 1) Remove power from the unit prior to any cleaning operation.
- 2) Use a cotton cloth to gently and sparingly apply isopropyl alcohol only. Do not use cleansers or other solvents as they may damage the unit.
- 3) Allow the unit to dry completely prior to reapplying power.



Caution (refer to accompanying documents)



Caution, risk of electrical shock!

For more detailed cleaning instructions, see 6.2.

Table of Contents

1. Introduction	2
1.1 About This Manual	2
1.2 Features and Benefits of RMT Controllers	2
1.3 Specifications	4
2. Operation	5
2.1 RMT Front Panel	5
2.2 What Happens When You Power Up the Controller	6
2.3 Operation Basics	6
3. Enabling SafeChange and Setting Jumpers	7
3.1 Introduction	7
3.2 Checking Mainframe for SafeChange Capability	7
3.3 Enabling the SafeChange Feature	7
3.4 Adding a SafeChange Clip to the Mainframe	8
3.5 Jumper Settings	8
4. Setup and Installation	9
4.1 Prepare the Controller	9
4.2 Install the Controller	9
4.3 Apply Power to the Mainframe and Controller	9
4.4 Set Failsafe Output Percentage	9
4.5 Adjust the Setpoint	10
5. Error Messages	10
5.1 Introduction	10
5.2 Summary of Error Messages	10
6. Maintenance	11
6.1 Introduction	11
6.2 Cleaning the Front Panel	12
6.3 Replacing the Fuses	12
6.4 Unit Repairs	12
7. Frequently Asked Questions	13
7.1 Introduction	13
7.2 FAQs	13
Index	14
Two-Year Limited Warranty	15

1. Introduction

1.1 About This Manual

This manual contains all the information needed to set up and operate the Series RMT Hot Runner controllers.

Instructions for wiring, installing, and troubleshooting the controllers are in the manual supplied with the mainframe.

1.2 Features and Benefits of RMT Controllers

1.2.1 Introduction

The Series Series RMT Hot Runner controllers offer many advanced features designed to increase productivity and ensure fast, accurate, and repeatable mode temperature control based on input from a J thermocouple.

An RMT is designed to control two temperature zones. The second zone on an RMT controller can be disabled with a jumper; see 3.5.

1.2.2 Convenient User Interface

RMT units have a two-line display for each zone. These bright LED displays are easy to read over wide viewing angles.

The zone's process value is displayed on the top line of the zone display (three digits).

The lower line (three digits) displays the zone's setpoint (closed loop mode) or output percentage (manual mode).

RMT units have two sets of indicators and LEDs on the front panel, one set for each zone. An orange indicator for the zone indicates heater on, and an orange LED for the zone indicates high or low process alarm.

Front panel keys make it easy to change mode, and to change the setpoint (closed loop mode) or output % (manual mode).

Detailed instructions for using the front panel are in Section 2.

1.2.3 PID Control

In closed loop (automatic) mode each Series RMT controller uses a single TRIAC output (per zone) to implement Proportional-Integral-Derivative (PID) control.

The incremental integral algorithm used by the Series RMT controllers never requires tuning.

1.2.4 Soft Start for Heater Bake Out

All Series RMT Hot Runner controllers support a soft start feature to extend the life of the heaters and the molds. The soft start allows slow dissipation of moisture in heaters by gradually applying power to the heaters.

When a soft start is executed, phase angle firing starts at 5% output power and steps up the output 5% every 30 seconds. The soft start lasts five minutes or until the process temperature reaches 200 °F (93 °C).

The orange soft start indicator is on during soft start in closed loop (auto) mode.

You can stop the soft start by pressing the MODE key to take the controller out of closed loop (auto) mode, and then use the MODE key to return the controller to closed loop mode.

A soft start is executed:

- every time the controller starts and the process value is less than 200 °F (93 °C), and
- every time the controller is returned to closed loop (auto) operation and the PV is less than 200°F (93 °C).

More information about the start up sequence is in 2.2.

1.2.5 Process Protection Features

1.2.5.1 Deviation Alarms

Each Series RMT Hot Runner controller supports configurable deviation alarms. A zone's orange ALARM LED (on the front panel) lights if the process value;

- falls below the zone setpoint minus the low alarm value, or
- rises above the zone setpoint plus the high alarm value.

The alarm status indicator remains lit as long as the process value deviates from the setpoint by at least the configured deviation alarm value.

While a zone is in alarm, **HI** or **LO** is also displayed.

The default high and low deviation alarm values are 30 °F (17 °C). Instructions for changing these defaults are in 4.4.

1.2.5.2 Loop Break Detection

The controller monitors the input change. If the input value does not change within 999 seconds while the controller is operating in closed loop (auto) mode, the controller goes to manual mode with 0% output, which can then be adjusted.¹

1.2.5.3 Sensor Error Monitoring

The controller can detect a reversed sensor or open sensor. See 5.2 for details.

1.2.6 Ease of Setup

A jumper makes it easy to change the unit of measure. The default is degrees Fahrenheit for North America and degrees Celsius for other shipping destinations.

¹ Loop break detection can be disabled using the setup menu; see 4.4.

1.3 Specifications

1.3.1 Operating Limits

Ambient Temperature 32 °F to 150 °F (0 °C to 65 °C)

Relative Humidity Tolerance 10 to 95 % Non-Condensing

Shipping Temperature -40 °F to 158 °F (-40 °C to 70 °C)

Power Requirements 115 to 240 Vac 50 or 60 Hz nominal, CE compliant

1.3.2 Performance

Temperature Accuracy ± 0.3 % of span

Setpoint Resolution 1 degree Fahrenheit

Repeatability ± 0.1 % of span

Temperature Stability ± 0.5 % of full scale over the ambient range of 32 °F to 150 °F (0 °C to 55 °C)

Thermocouple Cold-End Tracking automatic, better than 0.02 °F per degree Fahrenheit (0.02 °C per degree Celsius)

Noise Rejection Series Mode > 70 dB

Process Sampling Rate 10 Hz (100 ms)

1.3.3 Connections and Mounting

The Series RMT controllers are designed for installation in a Hot Runner mainframe (or other compatible mainframe). Removal of an RMT controller from the mainframe requires unlatching of a locking pin (standard controllers) or removal of a locking screw (CE-compliant controllers).

1.3.4 Inputs

Thermocouple J (grounded or ungrounded)

Supported Sensor Range 100 to 999 °F (37 to 537 °C)

1.3.5 Output

Voltages 240 Vac nominal, single phase; 120 Vac available

Power Capability 15 amperes, 3600 watts@ 240 Vac (This is the total for both channels.)

Overload Protection Triac and load use high speed fuses. Both sides of input power are fused (ABC; GBB optional).

Power Line Isolation Optically and transformer isolated from AC lines. Isolation voltage is greater than 2500 volts.

Output Drive Internal solid state TRIAC, triggered by AC zero crossing pulses for control (phase angle during soft start)

2. Operation

2.1 RMT Front Panel



Because an RMT model can control two zones, two sets of displays, keys, and indicators are provided. Zone B can be disabled; see 3.5.

1 – soft start indicator – lit (orange) when soft start is active

2 – output status indicator – lit (orange) when output is on

3 – process value (PV) display (orange)

4 – Celsius indicator – lit (green) when PV and SP are displayed in degrees C

5 – output percentage indicator – lit (green) when manual mode output % is displayed on lower line

6 – Fahrenheit indicator – lit (green) when PV and SP are displayed in degrees F

7 – setpoint (SP) display (closed loop mode) or output percent (manual mode)

8 – up key – increases setpoint (closed loop mode) or output percent (manual mode); press and hold for rapid change

9 – mode key – changes mode; active indicated by lit LED (12–13)

10 – down key – decreases setpoint (closed loop mode) or output percent (manual mode); press and hold for rapid change

11 – alarm indicator – lit (orange) when zone PV varies from the SP by the configured deviation alarm value (low or high)

12 – closed loop (normal) mode indicator – lit when automatic control is active

13 – manual mode indicator – lit (green) when output percent can be set by operator

14 – power switch

Power must be off when removing or installing controller.

2.2 What Happens When You Power Up the Controller

Turn on the controller by pressing the “I” end of the 16 A power switch on the front panel. When an RMT controller is powered up, it displays its firmware level.² Next, all segments of the display and all LED indicators light. The output remains off.

If you push the MODE button to put the controller into closed loop mode, the sequence of controller actions that follow and the state of the controller output depend on the process value. The controller does a soft start if the process value is less than or equal to 200 °F (93 °C).

You can stop soft start (not recommended) by pressing the **MODE** key repeatedly.

2.3 Operation Basics

2.3.1 See PV

To see the process value: Look at the top line of the display for the PV. The top line shows the PV for the zone, unless the controller detects an error.

2.3.2 See if Output is On

To see if the output is on: Look at the Heat indicator above the PV for the zone. This orange indicator is on when the output is on.

2.3.3 Monitor for Alarms

To watch for process alarms: Look at the orange ALARM LED.

This LED lights if the process value goes

above or below the zone setpoint by the configured deviation alarm value.

The alarm status indicator remains lit as long as the process value deviates from the setpoint by at least the configured deviation alarm value.

While a zone is in alarm, **HI** or **LO** is also displayed.

The default deviation alarm values are 30 °F (17 °C). Instructions for changing these defaults are in 4.4.

2.3.4 Change Mode

To change the mode: Press **MODE** to light the LED for the mode you want. The modes are:

- **closed loop** (auto control) – Controller uses the input value to calculate the output needed to maintain the setpoint shown on the lower line.
- **manual** (open loop control) – Controller output is the percent shown on the lower line. Input is ignored. Transfer from closed loop to manual is “bumpless” when the process value is within 9 °F (5 °C) of the setpoint.

2.3.5 Change Setpoint or Output

To change the setpoint (closed loop mode) or output (manual mode): Press the ▲ or ▼ key until the displayed value has been changed to the new value you want.

² It is a good idea to make a note of the firmware version number. If you phone for technical support, you will be asked for this version information, as well as for the complete model number of the controller in question.

3. Enabling SafeChange and Setting Jumpers

3.1 Introduction

Controllers are shipped with SafeChange disabled, because the controller will not work if the SafeChange feature is enabled, but the mainframe does not support SafeChange. You can enable SafeChange quickly and easily using a jumper as described in this section.

Basic set up choices are made using jumpers as described in this section. The jumpers in a Series RMT Hot Runner controller are set at the factory for Fahrenheit as the unit of measure for North America, and Celsius for other shipping destinations.

If you plan display the process value and enter the setpoint in the unit of measure that is not the default for your location, you must change the jumper setting.

Read and heed the warnings and cautions in the front of this manual before checking the mainframe for SafeChange capability or changing controller switch and jumper settings.

3.2 Checking Mainframe for SafeChange Capability

Do not enable SafeChange unless the mainframe supports this feature.

Use of the SafeChange feature does not eliminate the need for careful installation and removal of controllers. Always turn off power to the controller and the mainframe when installing or removing a controller.

To check the mainframe for SafeChange capability:



1. Turn off power to the mainframe.
2. Remove a blanking panel or a controller that is OFF, so you can look into the mainframe.

3. Look at the lower connector block on the backplane (shown below).
 - If a metal clip is in the third position in the connector block, then the mainframe supports SafeChange. You should enable SafeChange on the controller before installing it in the mainframe to reduce the possibility of damage to the controller; see 3.3.
 - If the third position in the connector block does not contain a metal clip, then the mainframe does not support SafeChange. You can add a clip to convert the mainframe; see 3.4.

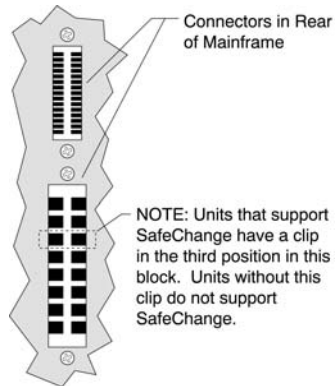

Location of Clip in Mainframe to Support SafeChange

3.3 Enabling the SafeChange Feature

Controllers are shipped with SafeChange disabled, because the controller will not work if the SafeChange feature is enabled, but the mainframe does not support SafeChange.

You can enable SafeChange quickly and easily.

To enable the SafeChange feature, remove the jumper block from JMP1.

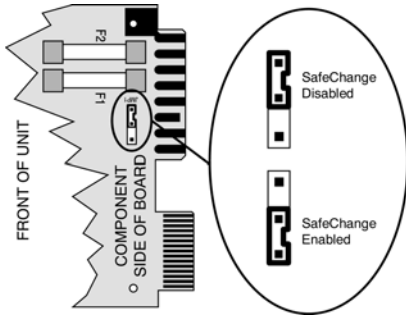

Location of SafeChange Jumper JMP1

If you don't see JMP1, the controller in hand may pre-date the SafeChange feature. In addition to JMP1 in the location shown above, controllers that support SafeChange also have one edge connector shorter than the others. If all the edge connectors are the same length, the controller does not support the SafeChange feature.

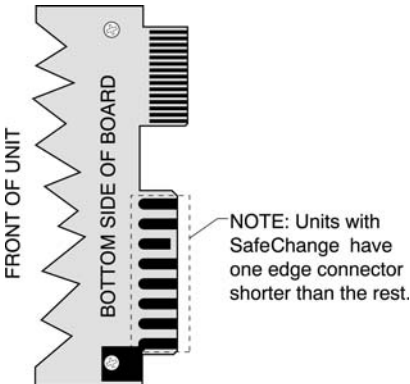

SafeChange Edge Connector

3.4 Adding a SafeChange Clip to the Mainframe

You can convert an older mainframe to support SafeChange. To make the conversion, you must add a clip to the third position in the lower connector block (on the backplane) in every slot; see the illustration in 3.2. The clip is p/n 216D001U01.

To install the clip:



1. Turn off power to the mainframe.
2. Remove the back cover of the mainframe.
3. Position the clip in the third (open) position in the lower connector block, and press. The clip will snap into position.

3.5 Jumper Settings

The jumpers in a Series RMT Hot Runner controller are set at the factory for Fahrenheit as the unit of measure for North America, and Celsius for other shipping destinations.

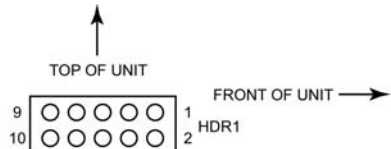

HDR1 Jumpers

Jumper on pins 1 & 2 = failsafe enabled; failsafe output percentage specified in setup menu is used. If failsafe is disabled, then output is zero if an open sensor is detected. Set up instructions are in 4.4.

Jumper on pins 3 & 4 = degrees Celsius (no jumper = degrees Fahrenheit)

Do not jumper pins 7 & 8.

Jumper on pins 9 & 10 = RMT second zone (B) disabled

4. Setup and Installation

4.1 Prepare the Controller

- Unpack the controller.
- Inspect the controller for damage.
- Make sure the power switch on the front of the controller is set to off (O).

If a controller shows signs of having been damaged during shipping, do not install or power up the controller. Save all packing materials and report any damage to the carrier immediately.

4.2 Install the Controller

This guide assumes that the mainframe has already been wired as described in the installation manual supplied with the mainframe.

- Make sure the plunger in center of the locking pin is pulled out (or loosen the locking screw).
- With the controller and mainframe power switches set to off (O), align the controller's printed circuit board with the guide channels in a slot in the Hot Runner mainframe.
- Slide the controller into the mainframe until the controller's connectors are firmly seated in the backplane of the mainframe.
- Lock the controller into the frame by pressing in the plunger on the locking pin (or tighten the locking screw).

4.3 Apply Power to the Mainframe and Controller

When the controller is powered up, the output may be activated.

- Before powering up the controller, consider the effects on your process if the output is activated. Take site-specific precautions.
- Turn on the power to the mainframe.

- Set the power switch on the front of the controller to on (I).

When the controller is powered up, the firmware version number is displayed. Next all segments of the displays and all LEDs are lit.

4.4 Set Failsafe Output Percentage

By default, the failsafe output percentage is set to zero. We strongly recommend that you use the setup menu to set this to a value suitable for your process.

While in the setup menu, you can also change the high and low deviation alarm values, and the loop break detection time from the defaults (if necessary).

Setup Menu Defaults

- ALo** alarm low – 30 degrees F
- AH** alarm high – 30 degrees F
- Lbt** loop break time – 5 minutes; if set to zero, loop break detection is disabled
- F-5** failsafe output 0 %

To access the setup menu for a zone:

- Press the zone's MODE key to enter manual mode.
- Press the ▲ to change the manual output percentage (lower line of display) to 2.
- Press and hold the MODE key for 3 seconds or until the upper display shows **ALo**.
- Release the MODE key.

To step through menu items (displayed on top line), press the MODE key.

To change the currently displayed value for a parameter (lower line), press the ▲ or ▼ key.

To exit the setup menu, cycle the power to the controller.

4.5 Adjust the Setpoint

When the controller is powered up and put into closed loop mode, the controller will automatically do a soft start for heater bake out if the process value is below 200 °F. (PV is on the top line of the display. SP is on the lower line.) During the soft start the soft start indicator is lit.

During the soft start (which lasts five minutes or until the PV is 200 °F), adjust the setpoint to a value that is representative of the setpoint you expect to use when the controller is in service.

To adjust the setpoint press the ▲ or ▼ key.

The display reverts to the closed loop mode operating display: PV on top line, SP on lower line.

RMT controllers do not require calibration.

The controller is ready to use.

5. Error Messages

5.1 Introduction

Usually the controller displays the process variable on the top line and the setpoint on the lower line of the display.

However, when the controller detects a problem with the input messages are displayed to alert you to conditions that require your immediate attention.

5.2 Summary of Error Messages

If the controller detects a problem, an error message will be displayed. These messages are summarized below.

	Open Sensor Detected	Loop Break Detected	Reversed Sensor Leads Detected
top line display	goes high first briefly (see Note 1 below), then OPn / tC	goes low first (see Note 1 below), then after five minutes Err	goes low first (see Note 2 below), then rEu / tC / changing numerical values
lower line display	0 (zero output %)	LDP / Ht	0 (zero output %)
output	off (0 %)	on while low, then off (see Note 1)	on while low, then off (see Note 2)
alarm LED	on	on	on

Note 1: At first, a falsely increasing process value is displayed on the top line; the setpoint remains on display on the lower line, and the output remains on until the process value is greater than the setpoint.

Note 2: At first, **L** alternates with display of the decreasing process value on the top line; the setpoint remains on display on the lower line, and the output remains on until the sensor error is detected.

6. Maintenance

6.1 Introduction

This section contains instructions for cleaning the front panel of the controller and instructions for replacing the fuses.

Except for fuses, the controller contains no user-serviceable parts.

Warning



Do not attempt to clean any part of a controller other than the front panel.

If you want to clean the front panel of a single controller, use the power switch on the front of the controller to turn it off, then remove the controller from the mainframe.

If you want to clean the front panel of several controllers, turn off all controllers in the mainframe and turn off power to the mainframe before cleaning the controllers while they are in the mainframe.

While cleaning a controller's front panel, do not allow alcohol to enter the switch.

Allow controllers and mainframes to dry thoroughly before restoring power. Do not use a heater or compressed air to dry the units.

Failure to observe these precautions can result in exposure to a potentially lethal shock hazard.

The controller power switch should be in the "OFF" position before you put a controller into an energized mainframe, or remove a controller from an energized mainframe. Failure to observe these precautions can result in damage to the connectors and printed circuit boards.

6.2 Cleaning the Front Panel



To clean an RMT controller:

1. Read the safety warnings above before you start cleaning a controller.
2. To clean the front panel of a single controller, put the controller power switch in the "OFF" position, and then remove the controller from the energized mainframe by pulling out the plunger on the locking pin (or loosening the locking screw), and pulling on the handle on the front of the controller.

Alternatively, if you plan to clean the front panel of several controllers, put the power switch of every controller in the mainframe in the "OFF" position, and then turn off power to the entire mainframe. After the mainframe has been de-energized, you can clean the controllers while they are in the mainframe.

3. Use a cotton cloth to gently and sparingly apply isopropyl alcohol to the front panel of the controller. Do not use cleaning solutions or other solvents. Use of anything other than isopropyl alcohol can result in damage to the controller.

Do not allow alcohol to enter the power switch on the controller's front panel.

4. Allow the controller to air-dry thoroughly. Do not use a heater or compressed air to dry the unit.
5. Inspect all surfaces to make sure that they are completely dry.
6. When the controller is completely dry, re-install it and return it to service.

6.3 Replacing the Fuses

Each RMT controller contains two fuses, located on the main printed circuit board.

To replace the fuses:

1. Make sure that you have the correct replacement fuse – Type F fast-acting 250 Vac fuses rated at 15 amps. Suitable fuses are p/n 210B001U01 and Littlefuse Inc. p/n 314015.
2. Put the power switch of the controller in the "OFF" position.
3. Pull out the plunger in the locking pin (or loosen the locking screw).
4. Use the handle on the front of the controller to pull it out of the mainframe.
5. Replace the fuses.
6. Re-install the controller and return it to service.

6.4 Unit Repairs

It is recommended that units requiring service be returned to an authorized service center. Before a controller is returned for service, please consult the service center nearest you. In many cases, the problem can be cleared up over the telephone.

When the unit needs to be returned, the service center will ask for a detailed explanation of problems encountered and a Purchase Order to cover any charge. This information should also be put in the box with the unit. Following these instructions should expedite return of the unit to you.

7. Frequently Asked Questions

7.1 Introduction

Before you call for technical support, please look at this section to see if your question is covered here. If you do call for technical assistance, be ready to supply the following information:

- complete model number of controller (and firmware version if known)
- symptoms of the problem
- unusual events, if any, that preceded the problem
- remedies you have already tried

7.2 FAQs

7.2.1 Do I have to calibrate a new controller?

No

7.2.2 Why doesn't the displayed PV match the value on a thermometer in the process?

Unless the thermometer and the sensor providing input to the controller are very close to one another, their readings will not match in some applications, because of temperature variations within the process.

7.2.3 I turned on the power; why doesn't the temperature rise?

If SafeChange is enabled, but the mainframe does not support SafeChange, the controller will not apply power to the heater. Instructions for checking to see if a mainframe supports SafeChange are in 3.2. Instructions for disabling SafeChange are in 3.3.

Index

A

alarms, 3, 5, 6, 9

B

bumpless transfer, 6

C

calibration, 10, 13
CE EMC compliance, II
changing setpoint or output, 6
cleaning controllers, 11
Closed Loop LED, 5

D

default jumper settings, 8
deviation alarms, 3, 5, 6, 9
disabling loop break detection, 9
disabling SafeChange, 7
disabling second zone, 8
displays, 5, 10

E

enabling loop break detection, 9
enabling SafeChange, 7
enabling second zone, 8
error codes, 10

F

factory default jumper settings, 8
failsafe output percentage, 9
front panel, 5
fuses, 12

H

Heat indicator, 5, 6

J

jumper setting, 7
jumper settings, 3, 7

L

loop break detection, 3, 9
loop break message, 10

M

maintenance, 11
Manual LED, 5
MODE key, 2, 5, 9
modes of operation, 6

O

open thermocouple, 10
output for control, 6
output in manual mode, 6
output state on power up, 6

P

part number for fuses, 12
part number for SafeChange clip, 8
powering up controller, 6
process value display, 5, 6

R

replacing fuses, 12
reversed thermocouple leads, 10

S

SafeChange feature, 7, 13
safety information, I, 11
sensor error, 3
setpoint, 5, 6
setup menu, 9
shorted thermocouple, 10
soft start, 3, 6
span calibration, 13

T

technical support, 13
troubleshooting, 10, 13

U

unit of measure jumper setting, 7, 8
user interface, 5
user-serviceable parts, 11

Z

zero calibration, 13

Two-Year Limited Warranty

This equipment is warranted to be free from defects of material and workmanship. It is sold subject to our mutual agreement that the liability of the seller is to replace or repair this equipment at its factory, provided that the equipment is returned with transportation prepaid within two (2) year of its purchase.

The purchaser agrees that the seller assumes no liability under any circumstances for consequential damages resulting from use of this equipment or from improper handling or packaging of shipments returned to the factory.

Components which wear or which are damaged by misuse are not warranted. These include contact points, fuses, electromechanical relays, and triacs. Units which have been modified by a customer in any way are not warranted.

Other than those expressly stated herein, there are no other warranties of any kind, express or implied, and specifically excluded but not by way of limitation, are the implied warranties of fitness for a particular purpose and merchantability.

It is understood and agreed the seller's liability whether in contract, in tort, under any warranty, in negligence or otherwise shall not exceed the return of the amount of the purchase price paid by the purchaser and under no circumstances shall seller be liable for special, indirect, incidental or consequential damages. The price stated for the equipment is a consideration in limiting seller's liability. No action, regardless of form, arising out of the transactions of this agreement may be brought by purchaser more than two years after the cause of action has accrued.

Seller's maximum liability shall not exceed and buyer's remedy is limited to either (i) repair or replacement of the defective part or product, or at seller's option (ii) return of the product and refund of the purchase price, and such remedy shall be buyer's entire and exclusive remedy. The specifications put forth in this manual are subject to change without notice.

