



T.C. HOLE SPECIFICATIONS



STANDARD T.C. HOLES

Standard on most nozzles

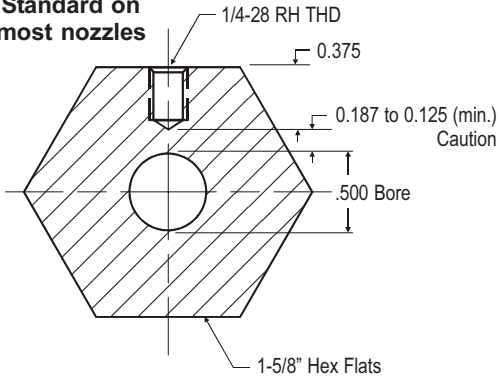

1/4-28 THD Bottoming Tap

Example shown is with a 1-5/8" hex and a 1/2" dia. internal bore. A larger bore requires a larger hex.

Part No. TC1428
PRICE: \$11.00

STANDARD (HMTc) MELT T.C. HOLES

3/8-24 N.F.

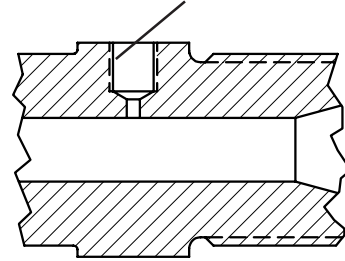

Part No. TC38HM
PRICE: \$25.00

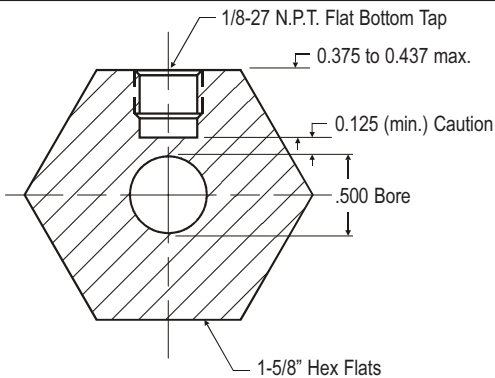

1/8-27 N.P.T. Flat Bottom Drill & Tap

Example shown is with a 1-5/8" hex and a 1/2" dia. internal bore. A larger bore requires a larger hex.

Part No. TC18PT
PRICE: \$11.00

3/8-24 N.F. SPECIAL 30° ANGLE MELT T.C. HOLE

Requires 1-7/8" across hex flats

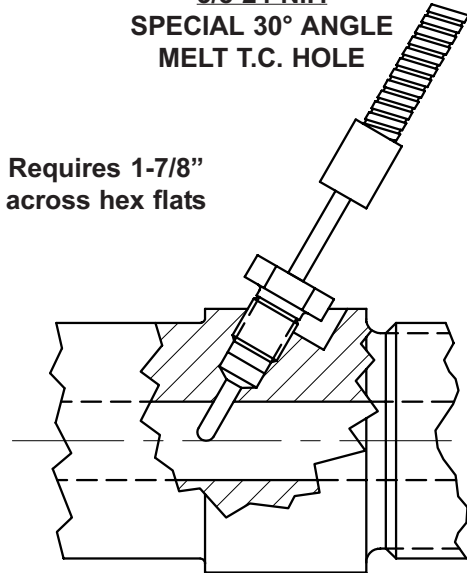

Part No. TC38HMA
PRICE: \$32.00

Full Taper Nozzles with 1" or larger rear openings require 2" hex for HMTc Melt T.C. hole.

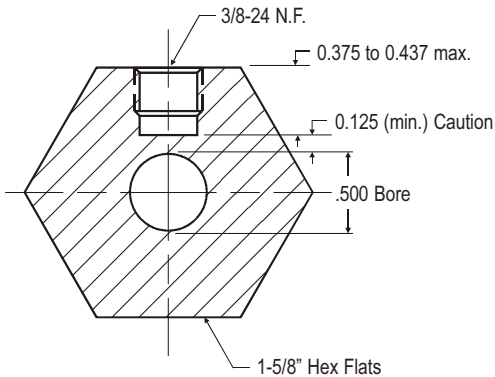

3/8-24 N.F. Flat Bottom Drill & Tap

Example shown is with a 1-5/8" hex and a 1/2" dia. internal bore. A larger bore requires a larger hex.

Part No. TC38NF
PRICE: \$11.00

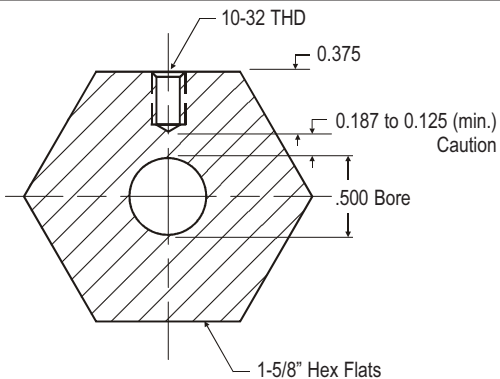

10-32 THD Bottoming Tap

Example shown is with a 1-5/8" hex and a 1/2" dia. internal bore. A larger bore requires a larger hex.

Part No. TC1032
PRICE: \$11.00

NEWBURY OEM STYLE T.C. HOLES

1/8 DIA

Through hole with set screw.

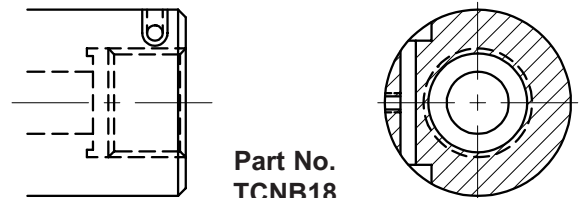

Part No. TCNB18
PRICE: \$17.50



PLASTIC PROCESS EQUIPMENT, INC.

8303 CORPORATE PARK DRIVE
MACEDONIA, OHIO 44056
216-367-7000 • FAX: 216-367-7022
TOLL FREE: 800-321-0562

6385 MONTESSOURI STREET
LAS VEGAS, NEVADA 89113
702-433-6385 • FAX: 702-433-6388
TOLL FREE: 800-258-8877

www.ppe.com

e-mail: sales@ppe.com

Toll Free: USA, Canada & Mexico

800-362-0706

Order Fax: 800-223-8305