



COLOR MIXING NOZZLES FOR HELIX MIXER SEGMENTS

Order Form (FILL IN THE DIMENSIONS)

JUST MAKE A
COPY OF
THIS FORM
IN IT'S ENTIRETY

REMOVABLE TIP DESIGN:

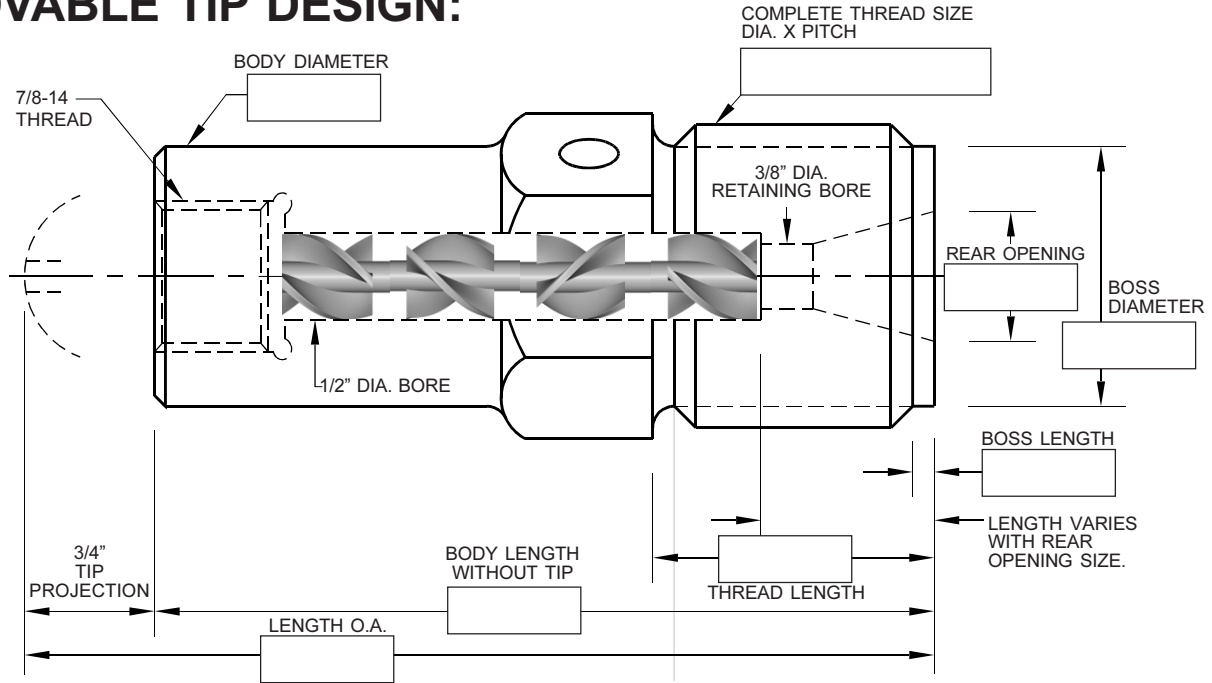

ALWAYS USE
A THREAD LUBE!

ALTERNATE VAN DORN V-17 ILLUSTRATED

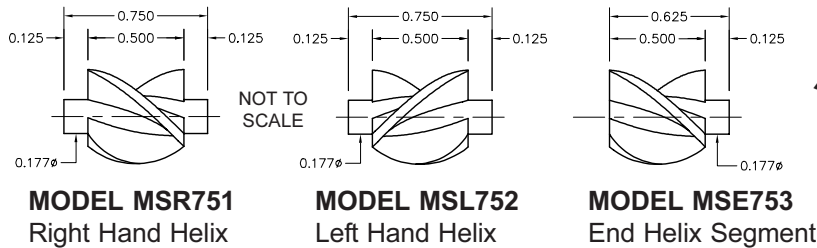

NOT TO SCALE

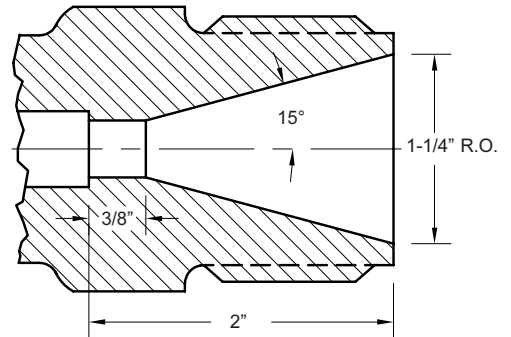

ALSO SPECIFY:

MACHINE MAKE & TYPE: _____
 TIP: INTERNAL DESIGN GENERAL PURPOSE NYLON FULL TAPER
 HEATED DESIGN: EXTERNALLY BAND HEATED INTERNALLY CARTRIDGE HEATED
 THERMOCOUPLE HOLE - THREAD SIZE & LOCATION: _____
 YOUR COMPANY _____ YOUR P.O. NUMBER _____
 ADDRESS _____ FAX NUMBER _____
 CITY _____ STATE _____ ZIP _____
 PERSON TO CONTACT _____ TELEPHONE _____

© Copyright 2022 Plastic Process Equipment, Inc. Note: PPE customers may reproduce this form only in it's entirety.



PLASTIC PROCESS EQUIPMENT, INC.

8303 CORPORATE PARK DRIVE
MACEDONIA, OHIO 44056
216-367-7000 • FAX: 216-367-7022
TOLL FREE: 800-321-0562

6385 MONTESSOURI STREET
LAS VEGAS, NEVADA 89113
702-433-6385 • FAX: 702-433-6388
TOLL FREE: 800-258-8877

www.ppe.com
e-mail: sales@ppe.com

Toll Free: USA, Canada & Mexico
800-362-0706

Order Fax: 800-223-8305