

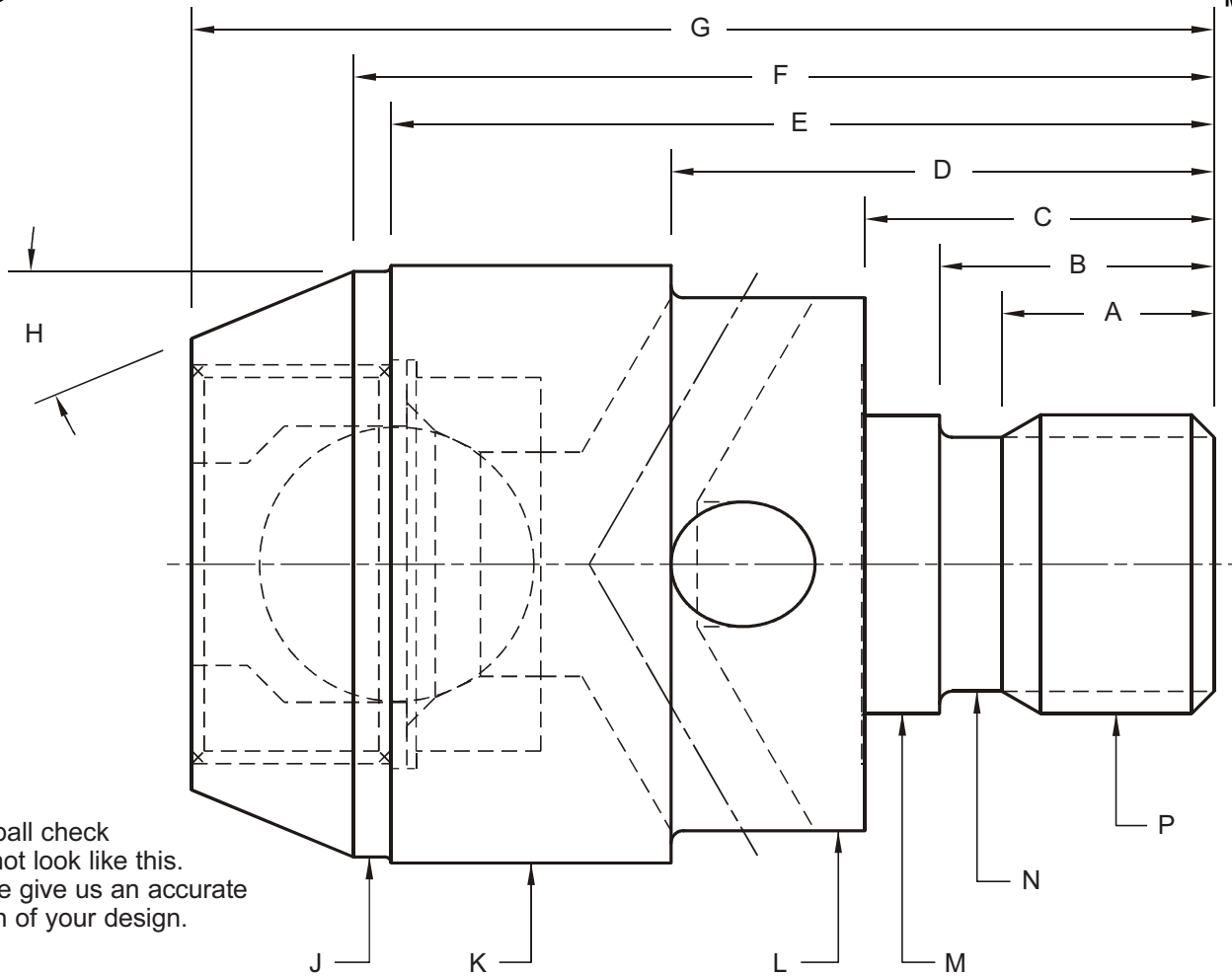

BALL CHECK SCREW TIPS



Your ball check may not look like this. Please give us an accurate sketch of your design.

MACHINE MAKE _____

A. THREAD LENGTH _____

B. RETAINER PILOT LENGTH _____

C. OVERALL THREAD END LENGTH _____

D. RING START DISTANCE _____

E. RING END DISTANCE _____

F. ANGLE START DISTANCE _____

G. OVERALL LENGTH _____

H. NOSE ANGLE _____

J. FRONT DIA _____

K. OUTSIDE DIA _____

L. END OF SCREW DIA _____

M. PILOT DIA _____

N. SHANK DIA _____

P. THREAD DIA & PITCH _____

NOTE: PLEASE BE AWARE - THE DIMENSIONS YOU ARE GIVING US ARE FROM WORN OR DAMAGED PARTS AND MAY NOT BE ACCURATE. FOR BEST ACCURACY, WE RECOMMEND THAT YOU SEND THE PARTS TO US.

YOUR COMPANY _____ YOUR P.O. NUMBER _____

ADDRESS _____ FAX NUMBER _____

CITY _____ STATE _____ ZIP _____

PERSON TO CONTACT _____ TELEPHONE _____

E-MAIL _____

© Copyright 2022 Plastic Process Equipment, Inc.
Note: PPE customers may reproduce this form only in it's entirety.



PLASTIC PROCESS EQUIPMENT, INC.

EAST 8303 CORPORATE PARK DRIVE
MACEDONIA, OHIO 44056
216-367-7000 • FAX: 216-367-7022
TOLL FREE: 800-321-0562

WEST 6385 MONTESSOURI STREET
LAS VEGAS, NEVADA 89113
702-433-6385 • FAX: 702-433-6388
TOLL FREE: 800-258-8877

www.ppe.com
e-mail: sales@ppe.com

Toll Free: USA, Canada & Mexico
800-362-0706

Order Fax: 800-223-8305