



PREMIUM CARTRIDGE HEATER STOCK LIST

STOCKED WITH 10" SWAGED-IN LEADS

MIX OR MATCH SIZES FOR
QUANTITY DISCOUNTS

* Special price for existing Watlow stock only.

Diameter	Sheath Length Inches	Volts	Watts	W/In ²	PREMIUM Part No. <small>SWAGED-IN LEADS</small>	* WATLOW Part No. & Price <small>CRIMPED-ON LEADS</small>	PREMIUM Quantity Pricing	
							1-11	12+
3/4"	8"	240	500	32	P6080-20500		\$40.75	\$38.75
	8"	120	750	48	P6080-10750		\$40.75	\$38.75
	8"	240	750	48	P6080-20750		\$40.75	\$38.75
	8"	240	1000	65	P6080-21000		\$40.75	\$38.75
	8"	240	1500	97	P6080-21500		\$40.75	\$38.75
	8"	240	2000	129	P6080-22000		\$40.75	\$38.75
	9"	240	1800	102	P6090-21800		\$44.70	\$42.45
	10"	240	1000	51	P6100-21000		\$48.60	\$46.15
	10"	240	1500	76	P6100-21500		\$48.60	\$46.15
	10"	240	2000	102	P6100-22000		\$48.60	\$46.15
	12"	240	1000	39	P6120-21000		\$56.35	\$53.55
	12"	240	1500	59	P6120-21500		\$56.35	\$53.55
	12"	240	2000	78	P6120-22000		\$56.35	\$53.55
	14"	240	1250	42	P6140-21250		\$64.15	\$61.00
	14"	240	2000	68	P6140-22000		\$64.15	\$61.00
	15"	240	1500	51	P6150-21500		\$68.10	\$64.75
	16"	240	1800	51	P6160-21800		\$72.05	\$68.45
	16"	240	4700	133	P6160-24700		\$72.05	\$68.45
	18"	240	2000	49	P6180-22000		\$79.80	\$75.80
	20"	240	2300	49	P6200-22300		\$87.60	\$83.25
24"	240	1375	24	P6240-21375		\$103.35	\$98.15	

RECOMMENDED MAXIMUM WATT DENSITIES

	200°F	400°F	600°F	800°F	1000°F
GOOD FIT (under .004)	250 w/in ²	225	200	150	100
MEDIUM FIT (.005-.009)	175	150	100	75	60
OPEN AIR OR POOR FIT	35	30	25	20	18
IN WATER	250				

CARTRIDGE HEATER RELEASE & HEAT TRANSFER FLUID BY WATLOW

Prevents heater seizure.

Watlube provides a barrier to high temperature oxidation, thus assuring quick heater removal even after extended service.

Permits higher watt densities.

Watlube permits you to use cartridge heaters in a closer fit without worrying about lengthy downtime for replacement.

Improves thermal conductance.

Heat transfers more quickly from heater sheath to the part when Watlube is used, thus the heater operates at lower temperatures. However, Watlube is not a substitute for proper fit.

Extends heater life.

Heaters of any wattage will give you longer service with the tighter fit made practical by Watlube.

Easy to apply.

Just brush a thin coat on the heater sheath with the applicator provided. Avoid Watlube contacting the leads or end plug.

Available from stock.

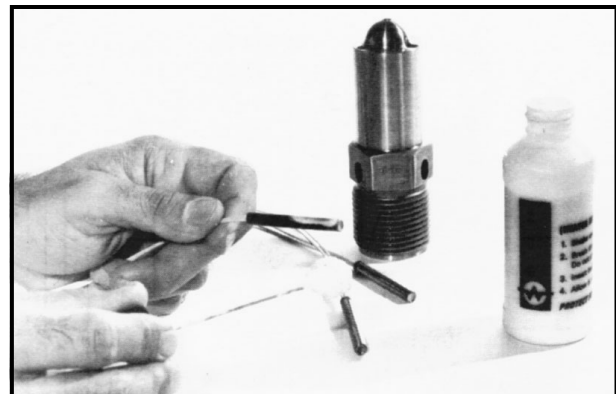

PRICES

4 ounce Plastic Bottle with Applicator

Part Number **HRF-4** **\$9.70ea.**



PLASTIC PROCESS EQUIPMENT, INC.

www.ppe.com • e-mail: sales@ppe.com

PPE WEST 6385 Montessouri Street, Las Vegas, Nevada 89113
702-433-6385 • 800-258-8877 • Fax: 702-433-6388

PPE SOUTH 11218 Challenger Avenue, Odessa, Florida 33556
727-834-8888 • 800-282-6783 • Fax: 727-834-8873

8303 CORPORATE PARK DRIVE, MACEDONIA (Cleveland), OHIO 44056, USA

216-367-7000 • Toll Free: 800-321-0562 • Fax: 216-367-7022 • Order Fax: 800-223-8305

**Toll Free: USA, Canada & Mexico
800-362-0706**