



AUTOMATIC CURRENT INDICATORS

TYPICAL APPLICATIONS & SIZES

REMOTE LED:

Current Ring Indicator with wire leads.
Part Number CR516WL

The CR516WL consists of the same current transformers as the basic CR516 except that wire leads are attached in place of the LED. The electrical specifications are identical to the basic CR516.

This version provides many varied applications:

REMOTE LED: The leads may be attached directly to the CRPH for a remote indication of current flow. A variable resistor (not furnished) may be installed in one of the leads to change the turn on point of the LED.
CURRENT METER: The leads may be attached to a high impedance AC volt meter to indicate actual current levels. A load resistor (not furnished) is required to be placed across the two leads.

Indicating range:

- 2 to 100 amp with one wire pass
- 2.5 to 25 amp with two passes

Proportionally more sensitive with additional wire passes.

LED Panel Holder.

Part Number CRPH

This Panel Holder is attached directly to the CR516WL to provide a remote indication of current flow. The Panel Holder requires only a 1/4 inch diameter hole for mounting. The holder is constructed from black nylon and is held in place with the plastic locking tabs. A current limiting resistor is installed in one of the leads. The Panel LED may be attached with up to 200 feet of #16 AWG wire.

Detailed technical and installation data is supplied with each unit.

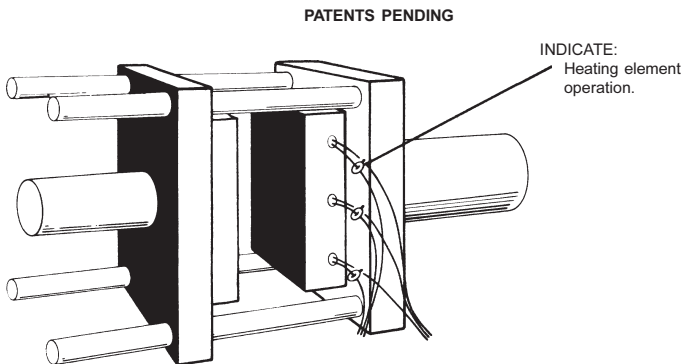

PROCESS HEATING

SPECIFICATIONS

CR516 & CR516G

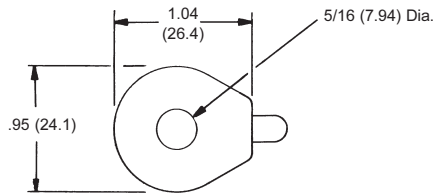

CR516WL

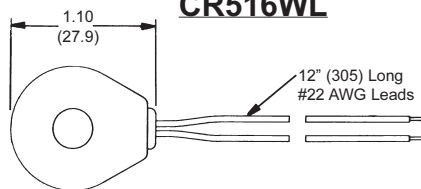

PH31

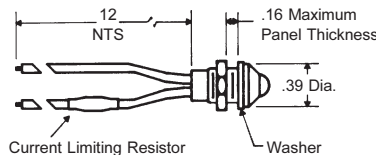

REQUIRES A .312 DIA. HOLE

MB516

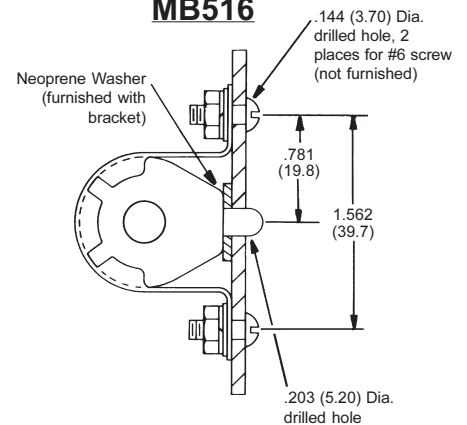

CRPH

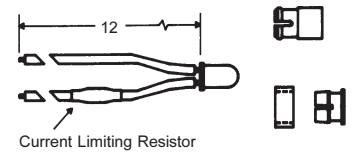

REQUIRES A .250 DIA. HOLE

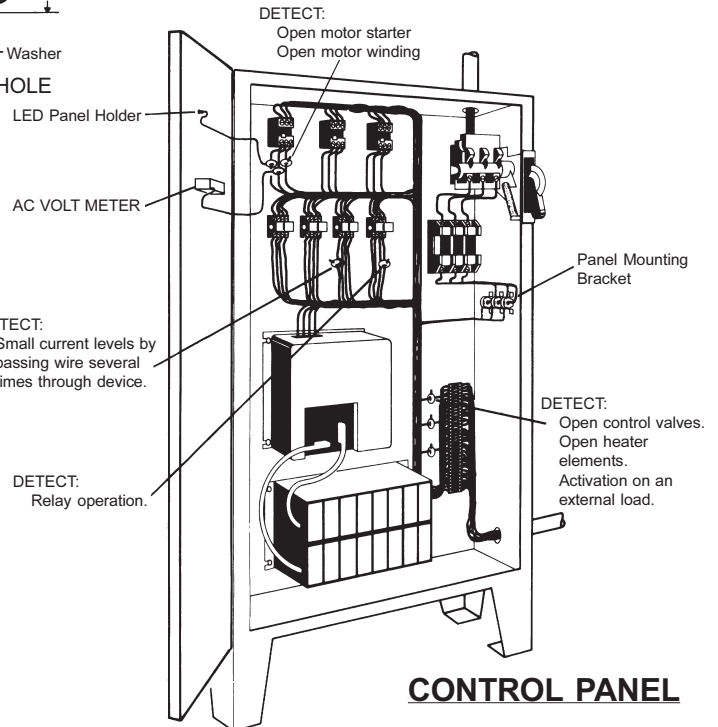

CONTROL PANEL



PLASTIC PROCESS EQUIPMENT, INC.

6385 Montessouri Street, Las Vegas, Nevada 89113
702-433-6385 • 800-258-8877 • Fax: 702-433-6388

11218 Challenger Avenue, Odessa, Florida 33556
727-834-8888 • 800-282-6783 • Fax: 727-834-8873

www.ppe.com • e-mail: sales@ppe.com

8303 CORPORATE PARK DRIVE, MACEDONIA (Cleveland), OHIO 44056, USA

216-367-7000 • Toll Free: 800-321-0562 • Fax: 216-367-7022 • Order Fax: 800-223-8305

Toll Free: USA, Canada & Mexico
800-362-0706