



# Han® INDUSTRIAL CONNECTORS



## FOR HOT RUNNER CONTROLS, MOLDS, ROBOTS, MACHINES, ACCESSORIES, DATA, ETC.

HARTING Han® Industrial Connectors are suited for the harshest requirements in industrial environments. They are used in all applications requiring a safe and removable electrical connection. The field of application for HARTING connectors is in protected electrical areas; for example in control cabinets to outdoor applications.

The Han® Industrial product line incorporates small connectors capable of a few amps up to large multi-way high power connections. The possible combination of connectors is large enabling sensitive signals of a few millivolts, as used in the field of Gigabit transmissions, up to 600 Amps or 5000 Volts for high power applications.

Full Line  
Han® Industrial  
Connectors  
Distributor



## Han® 3 A Series Housings & Hoods

### Housings - Panel Mount

Part No.	Description	Price
0920-0030320	Plastic Housing	\$5.60
0920-0030301	Metal Housing	7.95
0920-0030306	Metal Housing, with Cover	25.95
0920-0030820	Plastic Housing, 90° Angle	7.25
0920-0030801	Metal Housing, 90° Angle	12.10

Replacement Lever (Plastic Housing only)  
Part No. 0900-0005241 ..... \$3.40 ea.  
Replacement Gasket (Buna-N) - Part No. 0920-0009991 ..... \$.95 ea.

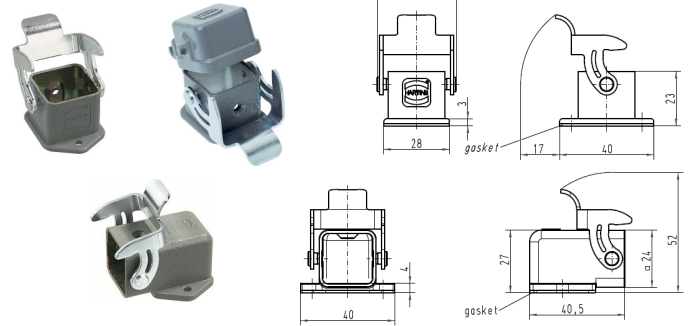

### Housings\* - Surface Mount

Part No.	Description	Thread (M)	Price
0920-0030220	Plastic Housing	PG-11	\$11.95
0920-0031252	Metal Housing	PG-11	16.75
1920-0030220	Plastic Housing	M20	7.90
1920-0031252	Metal Housing	M20	16.95

\*Order Strain Relief Gland separately (listed beyond).

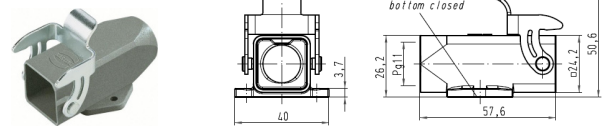

### Hoods\*

Part No.	Description	Thread (M)	Price
0920-0030420	Plastic Hood, Top Entry	PG-11	\$3.90
1920-0030420	Plastic Hood, Top Entry	M20	3.80
0920-0031440	Metal Hood, Top Entry	PG-11	6.45
1920-0031440	Metal Hood, Top Entry	M20	6.30
0920-0030620	Plastic Hood, Side Entry	PG-11	6.80
1920-0030620	Plastic Hood, Side Entry	M20	5.50
0920-0031640	Metal Hood, Side Entry	PG-11	10.95
1920-0031640	Metal Hood, Side Entry	M20	9.95

\*Order Strain Relief Gland separately (listed beyond).

### Hoods\* - Cable to Cable

Part No.	Description	Thread (M)	Price
0920-0030720	Plastic Hood, Top Entry	PG-11	\$7.95
1920-0030720	Plastic Hood, Top Entry	M20	6.85
0920-0031750	Metal Hood, Top Entry	PG-11	13.95
1920-0031750	Metal Hood, Top Entry	M20	10.95

\*Order Strain Relief Gland separately (listed beyond).

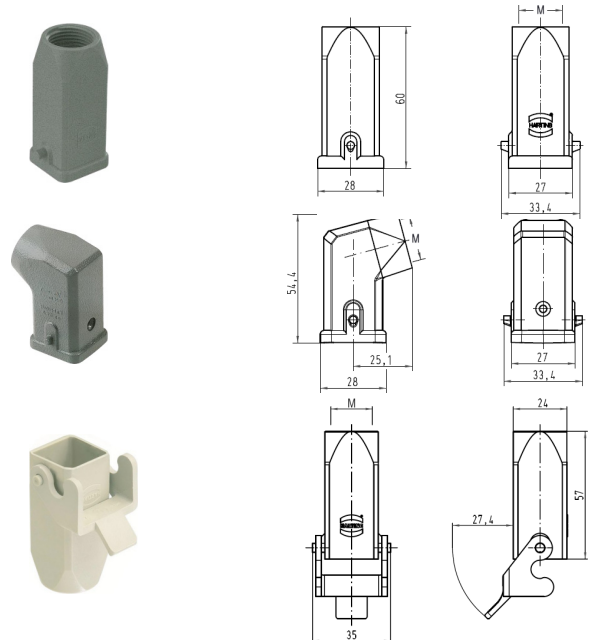

## PLASTIC PROCESS EQUIPMENT, INC.

6385 Montessouri Street, Las Vegas, Nevada 89113  
702-433-6385 • 800-258-8877 • Fax: 702-433-6388

11218 Challenger Avenue, Odessa, Florida 33556  
727-834-8888 • 800-282-6783 • Fax: 727-834-8873

8303 CORPORATE PARK DRIVE, MACEDONIA (Cleveland), OHIO 44056, USA

216-367-7000 • Toll Free: 800-321-0562 • Fax: 216-367-7022 • Order Fax: 800-223-8305

www.ppe.com • e-mail: sales@ppe.com

Toll Free: USA, Canada & Mexico  
**800-362-0706**