



PNEUMATIC LINE MAGNETS

RARE EARTH - PLM SERIES

QUICK CLEAN DESIGN



APPLICATION: PLM Series Pneumatic Line Magnets are designed for use in dilute-phase pneumatic processing systems. Pneumatic Line Magnets effectively remove inbound tramp metal contaminants from product streams conveyed by air in both horizontal and vertical processing and transfer lines. Typical applications include powder or granular food products, pharmaceuticals, plastics and chemicals conveyed at high speeds in low density/high air systems.

OPERATION: Pneumatic Line Magnets easily install in an existing conveying line, and are designed to maintain a continuous flow through the housing with no reduction in velocity. The nose cone diverts the product stream over the stainless steel sleeve assembly, which is ribbed at the magnetic pole areas to maximize tramp metal retention as the product flows over and around the sleeve. The magnet is cleaned by first removing the housing access door, which contains the magnetic assembly. The magnetic element is contained with the sleeve, and is easily removed. The element is pulled from the sleeve, allowing ferrous tramp iron to fall to be easily removed or discharged into a collection tray.

PLM CUTAWAY VIEW OF PRODUCT FLOW-THROUGH

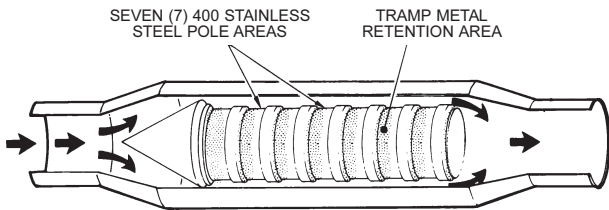

52 MGOe RARE EARTH MAGNETS ARE 10 TIMES MORE POWERFUL THAN STANDARD MAGNETS

FEATURES

- Exclusive removable magnetic element for quick, easy cleaning.
- Permanent Rare Earth magnet material, will not demagnetize.
- 100% 304 stainless steel enclosed design.
- Seven 400 series stainless steel pole areas.
- All stainless steel product flow contact area.
- Can be located anywhere in pneumatic lines.
- Trap tramp metal before it reaches your vital equipment.
- Closed cell food grade compression style flat gasket around access door to prevent product leakage.
- Removable housing access door with quick-release latches.
- Rugged all welded construction.

A MUST TO STOP SPEEDING TRAMP METAL!

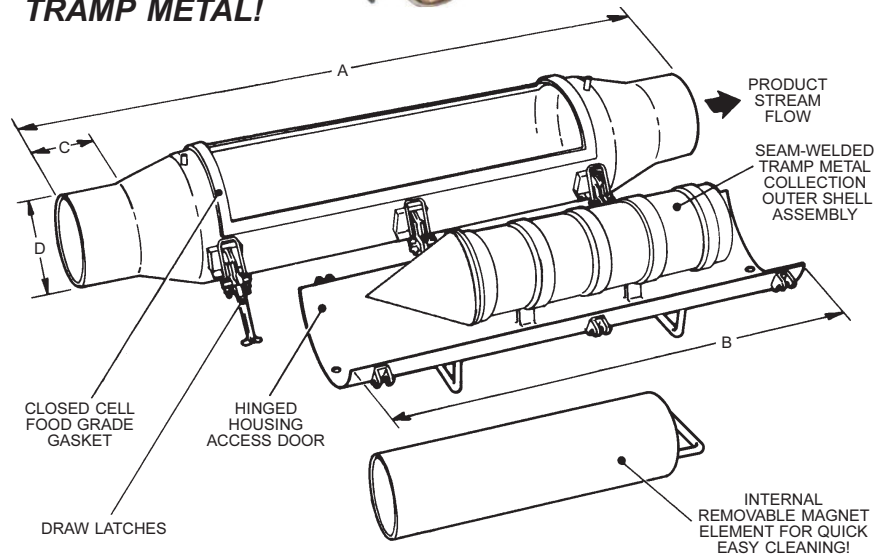

OTHER OPTIONS

- Non-standard alloy stainless steel construction.
- Special mounting flanges and matching companion flanges.
- Special pipe diameters.

CALL FOR QUOTE



SHOWN WITH SPECIAL MOUNTING FLANGES

RARE EARTH WITH QUICK CLEAN

PART NO.	PRICE EACH	"A" O.A.L.	"B" Door	"C" Flange	"D" O.D.	UNIT WEIGHT
PLM3REQC	\$5,951.50	38"	24"	3.0"	3.0"	72 lbs.
PLM4REQC	\$5,951.50	38"	24"	3.0"	4.0"	79 lbs.
PLM5REQC	\$7,485.75	38"	24"	3.0"	5.0"	93 lbs.
PLM6REQC	\$9,188.75	38"	24"	3.0"	6.0"	106 lbs.
PLM8REQC	CALL	50"	36"	4.5"	8.0"	155 lbs.
PLM10REQC	CALL	50"	36"	4.5"	10.0"	175 lbs.



PLASTIC PROCESS EQUIPMENT, INC.

8303 CORPORATE PARK DRIVE
MACEDONIA, OHIO 44056
216-367-7000 • FAX: 216-367-7022
TOLL FREE: 800-321-0562

6385 MONTESSOURI STREET
LAS VEGAS, NEVADA 89113
702-433-6385 • FAX: 702-433-6388
TOLL FREE: 800-258-8877

www.ppe.com

e-mail: sales@ppe.com

Toll Free: USA, Canada & Mexico

800-362-0706

Order Fax: 800-223-8305