



TRANSPARENT HOSE

FOOD GRADE PVC-SYNTHETIC YARN REINFORCED

– OBSERVE YOUR FLUID FLOW –

CONSTRUCTION:

A high quality seamless PVC core, reinforced with high tensile strength synthetic yarn and a tough abrasion resistant cover. It is made with compounds using ingredients shown on the FDA approved list.

APPLICATIONS:

Air, Water or Mild Chemicals

TEMPERATURE RANGE:

-12°C to +54°C OR -10°F to +150°F

FEATURES

- High Working Pressures
- See Through Convenience
- Light Weight
- Highly Flexible
- Excellent Bend Radius Min. Bend Radius 5 x I.D.
- Electrically Non-Conductive
- Resistant to Most Chemicals
- Non-Marking
- Weather/Aging Resistant
- Ideal for Use on Chillers
- Food Grade PVC
- Approved for use in USDA Meat & Poultry Plants.

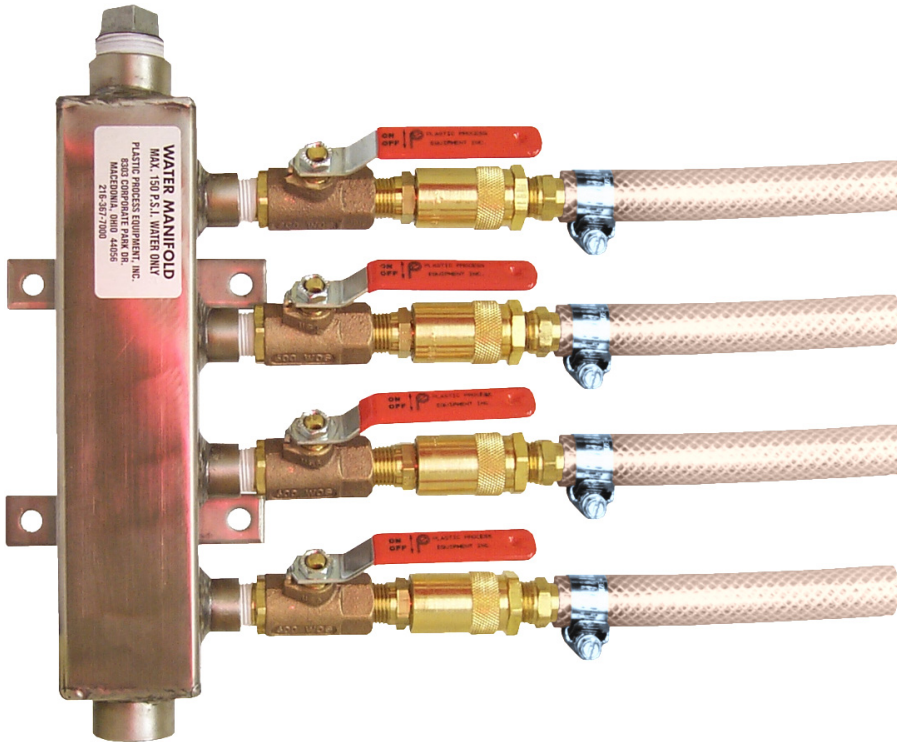

PART NO.	HOSE I.D. INCH	HOSE O.D. INCH	WORKING PRESSURE @ 70°F P.S.I.	ROLL QTY.	QUANTITY PRICES PER FT.	
					10-299 FT.	300+ FT.
102-02	1/8"	.312 in.	250	300 FT.	\$.22	\$.19
102-03	3/16"	.375 in.	250	300 FT.	.22	.20
102-04	1/4"	.468 in.	250	300 FT.	.22	.21
102-05	5/16"	.525 in.	250	300 FT.	.30	.28
102-06	3/8"	.625 in.	200	300 FT.	.35	.33
102-08	1/2"	.750 in.	200	300 FT.	.47	.44
102-10	5/8"	.875 in.	200	300 FT.	.58	.56
102-12	3/4"	1.031 in.	150	300 FT.	.71	.68
102-13	1"	1.312 in.	125	100 FT.	1.03	.99
102-14	1-1/4"	1.750 in.	100	100 FT.	1.72	1.64
102-15	1-1/2"	2.000 in.	75	100 FT.	2.16	2.07
102-16	2"	2.500 in.	75	100 FT.	3.45	3.30



PLASTIC PROCESS EQUIPMENT, INC.

www.ppe.com • e-mail: sales@ppe.com

PPE WEST 6385 Montessouri Street, Las Vegas, Nevada 89113
702-433-6385 • 800-258-8877 • Fax: 702-433-6388

PPE SOUTH 11218 Challenger Avenue, Odessa, Florida 33556
727-834-8888 • 800-282-6783 • Fax: 727-834-8873

8303 CORPORATE PARK DRIVE, MACEDONIA (Cleveland), OHIO 44056, USA

Toll Free: USA, Canada & Mexico

PPE 216-367-7000 • Toll Free: 800-321-0562 • Fax: 216-367-7022 • Order Fax: 800-223-8305

800-362-0706