



ME Sliding Nippers

*** It can be attached TS-564 silicone or TP-564 PU tube
match with MEB-3510-10/20 or MEB-2030-10/20
nipper mounting bracket

ME - Nipper Bodies

Part#	ΦCut	Stroke	Side Action	Weight	Air Pressure	Price
ME-3	1.0mm	3mm	Pull	170g	57~71psi	\$167.63
ME-5	1.2mm	3mm	Pull	290g	57~71psi	\$187.27
ME-10	2.5mm	3mm	Pull	540g	57~71psi	\$225.13
ME-20	4.5mm	5mm	Pull	810g	71~85psi	\$243.80
ME-30	6.0mm	5mm	Pull	1500g	71~85psi	\$366.23

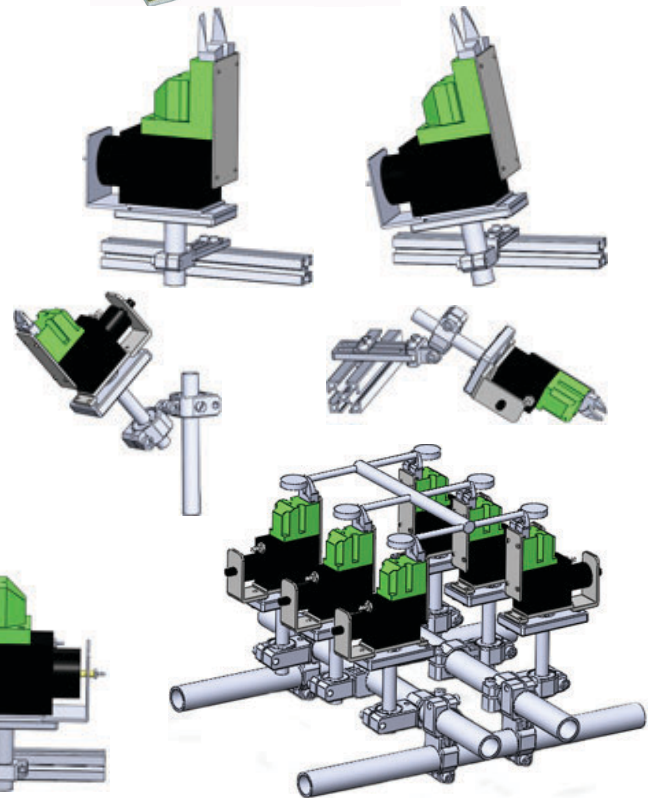
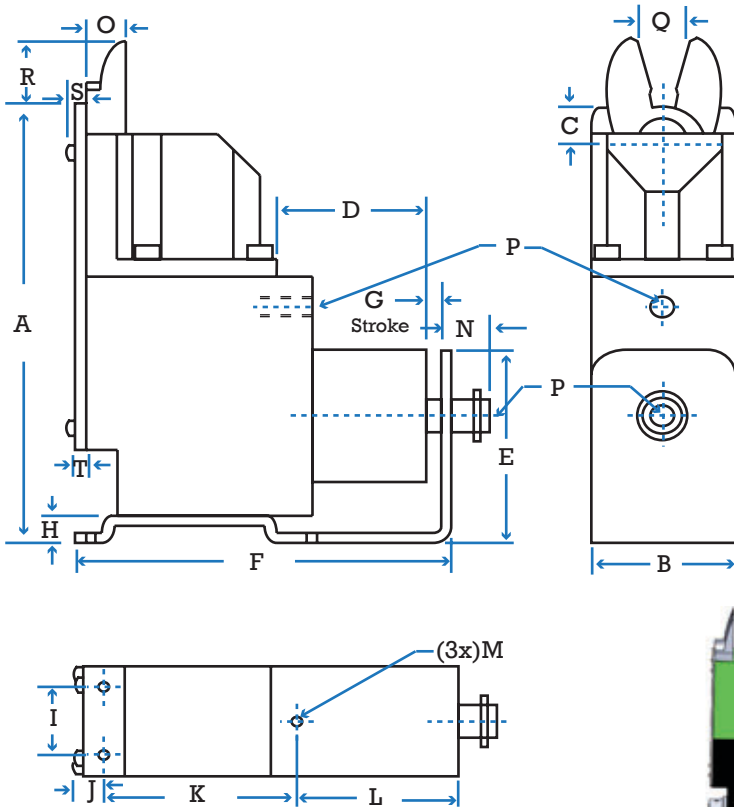

ME - Nipper Body Dimensions

Part#	A	B	C	D	E	F	G	H	I	J	K	L	M	N	O	P	Q	R	S	T
ME-3	74.2	20	8	33	34.2	71.2	3	6.2	14	2.5	50	18.7	M3	12.1	7	M5	3.5	21	3.3	2
ME-5	75.2	29	9	30	31.2	77.2	3	6.2	22	5	50	22.2	M3	12.1	7	M5	5.5	21	4.0	2
ME-10	97.2	35	10	39	42.2	88.2	3	6.2	26	5	50	33.2	M3	13	9	M5	7.0	21	4.0	2
ME-20	111.2	44	13	42	48.2	103.2	5	6.2	34	5	85	33.2	M4	13	12	M5	9.0	27	2.3	2
ME-30	149.2	56	15	51	64.2	127.2	5	6.2	40	7	85	35.2	M4	14	17	M5	15.0	50	3.3	3

Pull Action

