

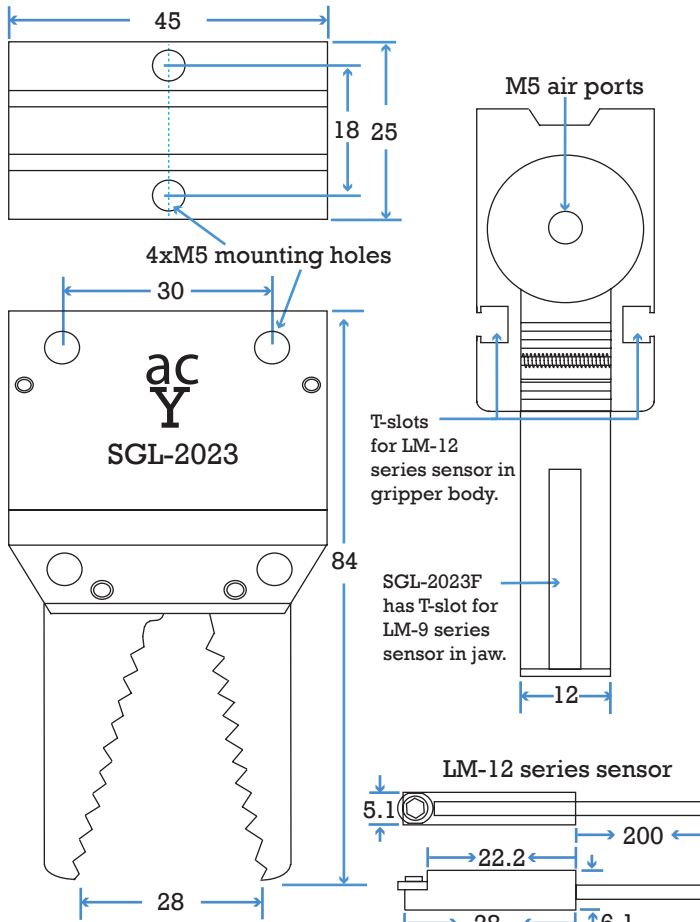

Slide Sprue Grippers

*** It can attached BF-6, BF-5 M5 male barbed fitting or M5 male connector push-in air fitting & mounting by SGLB-20-10/20, SMB-2395-66/88 gripper mounting bracket

Single Action type : SGL-2023/F



Sensor-Slot drawing

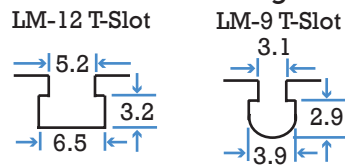

Max : 8 bar, Max : 116psi, Closing force : 23 (N)

| Part# | | Wt. | Price | Old Part# |
|-----------|---------------|------|----------|-----------|
| SGL-2023 | Single action | 114g | \$150.38 | TOPF110 |
| SGL-2023F | Single action | 116g | \$159.23 | |

1. Single acting with spring opening
2. High grip force
3. Providing 3 mounting sides
4. Hard anodized aluminum for jaws
5. with sensors optional



SGL-2023 shown.

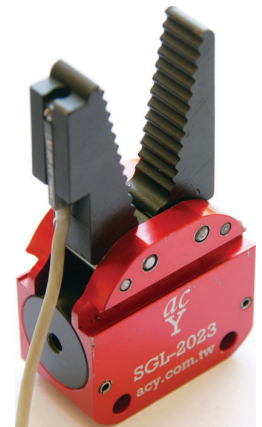

SGL-2023F shown with optional sensor LM-9 on jaw in T-slot.

Optional Sensor Type - 6-24 Volts DC

| Part# | Description | Price |
|---------|---|---------|
| LM-12N | NPN sensor 3-wire Hall effect with 2m leads | \$26.54 |
| LM-12NM | NPN sensor 3-wire Hall effect with M8 connector | \$27.42 |
| LM-12P | PNP sensor 3-wire Hall effect with 2m leads | \$31.85 |
| LM-12PM | PNP sensor 3-wire Hall effect with M8 connector | \$32.73 |
| LM-9N | NPN sensor 3-wire Hall effect with 2m leads | \$31.85 |
| LM-9NM | NPN sensor 3-wire Hall effect with M8 connector | \$32.73 |
| LM-9P | PNP sensor 3-wire Hall effect with 2m leads | \$33.62 |
| LM-9PM | PNP sensor 3-wire Hall effect with M8 connector | \$34.50 |

(Part# LM-12NM - Old Part# TOPF110S)

(Part# LM-9NM - Old Part# TOPF111AS)

Application Examples

