

SALE

DRYING HOPPERS WITH STAND AND CAST DISCHARGE CHUTE

STAINLESS STEEL INSULATED

9 SIZES AVAILABLE

SALE

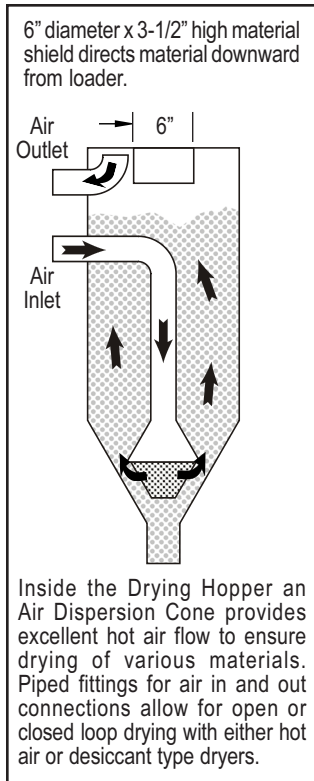

— INCLUDED —
Full size removable gasketed top Lid for easy cleaning.

2 Lifting Ears on top.

Thermocouple Port on incoming air pipe. M8 x 1.25mm thread

Double wall insulated hopper holds the heat.

Stainless Steel internal air pipes & dispersion cone.



OPTIONAL:
Mounting Bracket Assembly for Loader Proximity Switch Sensor. Attaches to Sight Glass Door. Switch not included.



ONE TIME SALE

FEB. 15, 2017 THRU JUN. 1, 2017

— INCLUDED —
6" dia. hole (covered) in top Lid for Material Loader.

Stainless Steel construction including interior, air pipes, and air dispersion cone. Inlet & Outlet sizes are listed in table.



Large gasketed hinged access door for easy inspection & cleaning.

Large Sightglass window to view materials. Large models have two.

— INCLUDED —
Sturdy all welded stand with casters

— INCLUDED —
Cast aluminum Discharge Chute with Material Shut-Off Slide Gate and lower Material Evacuate Slide Gate with lock. Sight Glass included. Bottom flange undrilled for future suction box or hopper mounting.

Discharge Chute Flange Plate: Top 7-3/8" dia. with 4 holes 3-7/8" on center. Bottom plate 6-1/4" x 6-1/4" square undrilled. See table for bottom opening sizes.



Model DH-750-USD
shown
775lb. Capacity

Model DH-120-USD
shown
140lb. Capacity

LIMIT 2 PER CUSTOMER

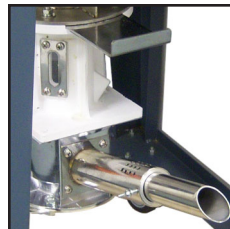

Suction Box available.

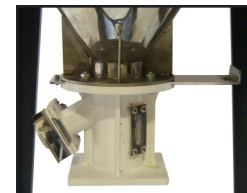

Our PPE Drying Hoppers are a PPE exclusive only available from PPE. Do not confuse these with any other make, model or manufacturer.

© Copyright 2015 Plastic Process Equipment, Inc.



PLASTIC PROCESS EQUIPMENT, INC.

www.ppe.com • e-mail: sales@ppe.com

PPE WEST 6385 Montessouri Street, Las Vegas, Nevada 89113
702-433-6385 • 800-258-8877 • Fax: 702-433-6388

PPE SOUTH 11218 Challenger Avenue, Odessa, Florida 33556
727-834-8888 • 800-282-6783 • Fax: 727-834-8873

8303 CORPORATE PARK DRIVE, MACEDONIA (Cleveland), OHIO 44056, USA

216-367-7000 • Toll Free: 800-321-0562 • Fax: 216-367-7022 • Order Fax: 800-223-8305

Toll Free: USA, Canada & Mexico
800-362-0706