



# Big Non-Rotating Suspensions

It can mount as follow

- M5, PT1/8 of FM/FP, BM/BP, BG, B2M/B2P series cup-adpater, adapter, push-in air fitting, barbed fitting
- Threaded type mounting with TMB-66/88 heavy angle plate
- Non threaded type mounting with swivel cross clamp, angle clamp, swivel angle clamp, angle arm, elbow arm



Non-threaded type

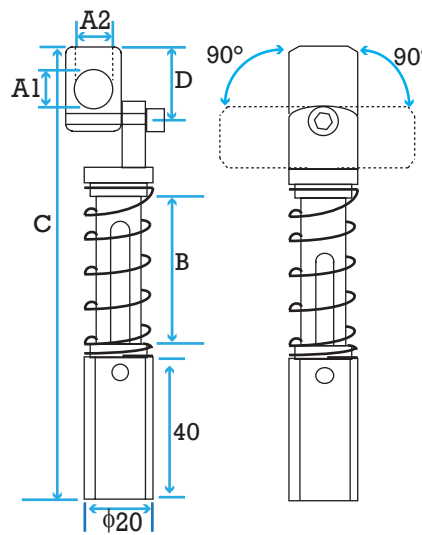

Threaded type

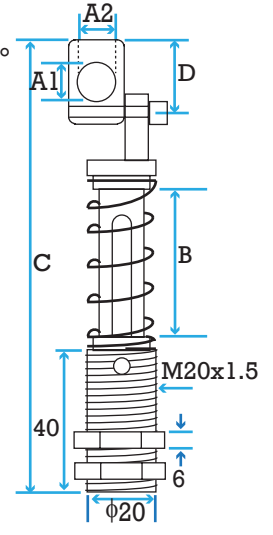

## Big Non-rotating Suspensions - Non-threaded body

Part#	A1	A2	B	C	D	Wt.	Price
NCG-2020-3M5	M5	M5	20	130	14	73g	\$36.27
NCG-2030-3M5	M5	M5	30	140	14	75g	\$38.04
NCG-2040-M5G8	M5	PT1/8	40	150	18	78g	\$39.81
NCG-2050-2G8	PT1/8	PT1/8	50	160	21	88g	\$41.40

## Big Non-rotating Suspensions - Threaded body

Part#	A1	A2	B	C	D	Wt.	Price
NCG-2020S-3M5	M5	M5	20	130	14	94g	\$36.27
NCG-2030S-3M5	M5	M5	30	140	14	97g	\$38.04
NCG-2040S-M5G8	M5	PT1/8	40	150	18	100g	\$39.81
NCG-2050S-2G8	PT1/8	PT1/8	50	160	21	110g	\$42.28

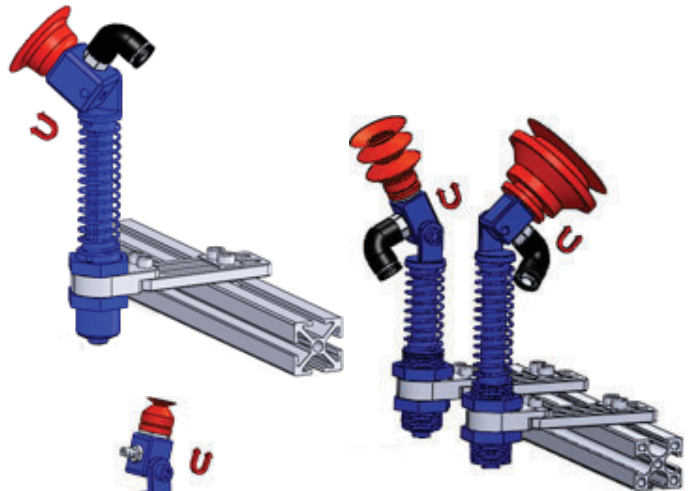

## Application Examples

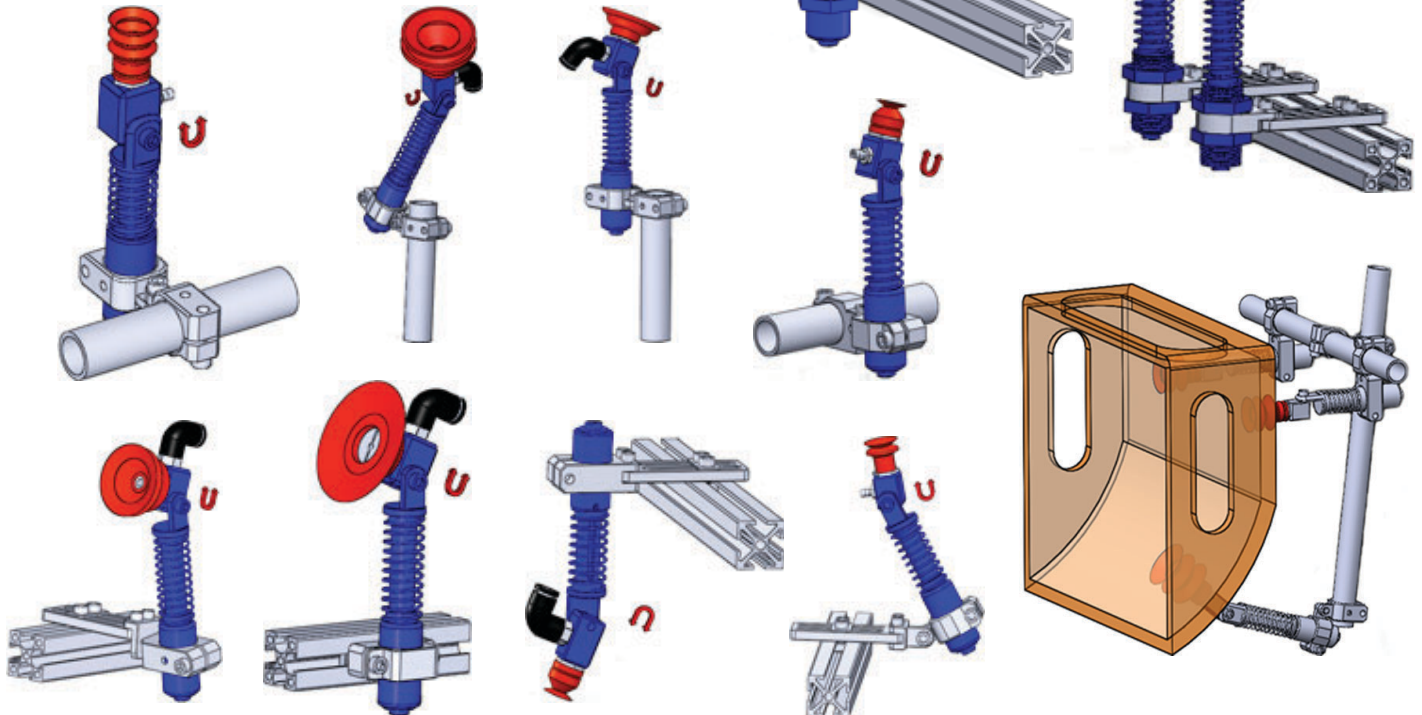

**PLASTIC PROCESS EQUIPMENT, INC.**

www.ppe.com • e-mail: sales@ppe.com

**PPE WEST** 6385 Montessouri Street, Las Vegas, Nevada 89113  
702-433-6385 • 800-258-8877 • Fax: 702-433-6388

**PPE SOUTH** 11218 Challenger Avenue, Odessa, Florida 33556  
727-834-8888 • 800-282-6783 • Fax: 727-834-8873

8303 CORPORATE PARK DRIVE, MACEDONIA (Cleveland), OHIO 44056, USA

Toll Free: USA, Canada & Mexico

216-367-7000 • Toll Free: 800-321-0562 • Fax: 216-367-7022 • Order Fax: 800-223-8305

**800-362-0706**