

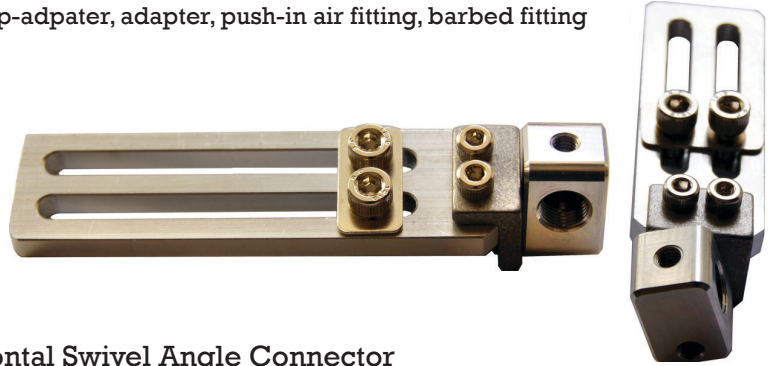

Swivel Vacuum Cup Connectors

As follow connectors can mount
M5, PT1/8 of FM/FP, BM/BP, BG, B2M/B2P series cup-adpater, adapter, push-in air fitting, barbed fitting

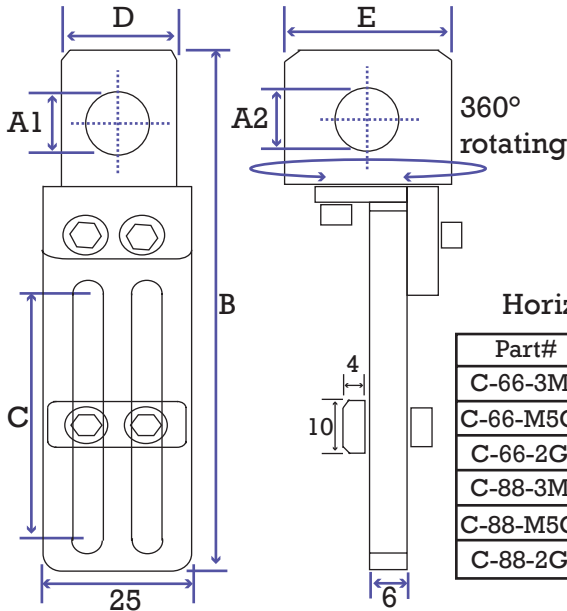

Horizontal Swivel Angle Connector

| Part# | Type | A1 | A2 | B | C | D | E | Wt. | Price |
|-----------|------|-------|-------|-----|----|----|----|-----|---------|
| C-66-3M5 | S | M5 | M5 | 91 | 48 | 20 | 25 | 54g | \$11.36 |
| C-66-M5G8 | S | M5 | PT1/8 | 91 | 48 | 20 | 25 | 53g | \$17.83 |
| C-66-2G8 | S | PT1/8 | PT1/8 | 91 | 48 | 20 | 25 | 59g | \$16.54 |
| C-88-3M5 | L | M5 | M5 | 113 | 68 | 20 | 25 | 59g | \$13.29 |
| C-88-M5G8 | L | M5 | PT1/8 | 113 | 68 | 20 | 25 | 58g | \$19.27 |
| C-88-2G8 | L | PT1/8 | PT1/8 | 113 | 68 | 20 | 25 | 64g | \$18.19 |

(right and left changeable)

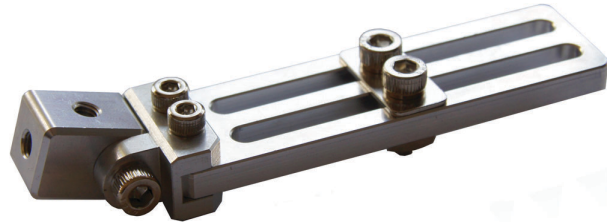
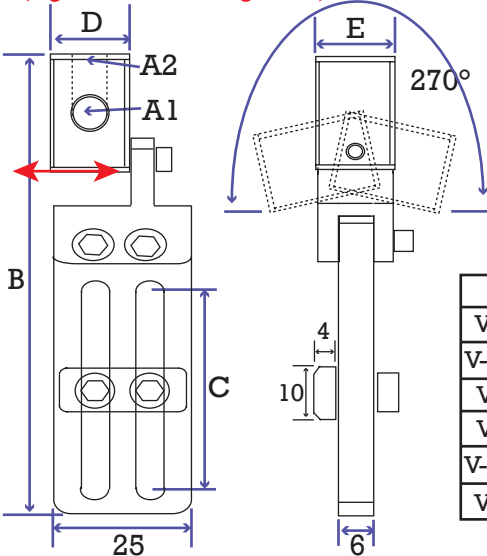

Vertical Swivel Angle Connector

| Part# | Type | A1 | A2 | B | C | D | E | Wt. | Price |
|-----------|------|-------|-------|-----|----|----|----|-----|---------|
| V-66-3M5 | S | M5 | M5 | 99 | 48 | 20 | 25 | 56g | \$13.29 |
| V-66-M5G8 | S | M5 | PT1/8 | 99 | 48 | 20 | 25 | 55g | \$19.96 |
| V-66-2G8 | S | PT1/8 | PT1/8 | 99 | 48 | 20 | 25 | 61g | \$18.17 |
| V-88-3M5 | L | M5 | M5 | 121 | 68 | 20 | 25 | 61g | \$14.77 |
| V-88-M5G8 | L | M5 | PT1/8 | 121 | 68 | 20 | 25 | 60g | \$21.37 |
| V-88-2G8 | L | PT1/8 | PT1/8 | 121 | 68 | 20 | 25 | 67g | \$19.14 |

Application Examples

Swivel horizontal

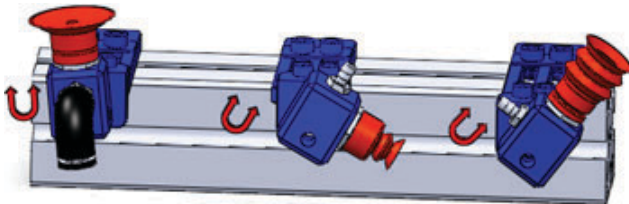

Swivel vertical

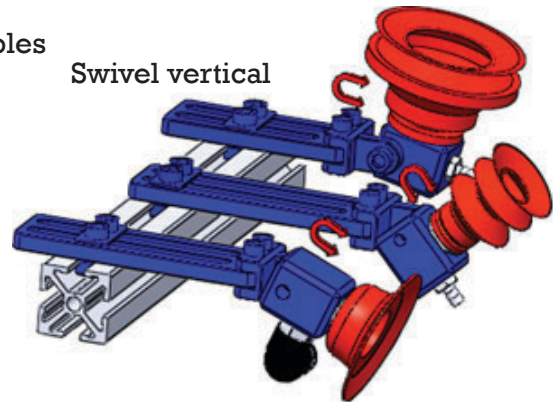

PLASTIC PROCESS EQUIPMENT, INC.

www.ppe.com • e-mail: sales@ppe.com

PPE WEST 6385 Montessouri Street, Las Vegas, Nevada 89113
702-433-6385 • 800-258-8877 • Fax: 702-433-6388

PPE SOUTH 11218 Challenger Avenue, Odessa, Florida 33556
727-834-8888 • 800-282-6783 • Fax: 727-834-8873

8303 CORPORATE PARK DRIVE, MACEDONIA (Cleveland), OHIO 44056, USA

Toll Free: USA, Canada & Mexico

216-367-7000 • Toll Free: 800-321-0562 • Fax: 216-367-7022 • Order Fax: 800-223-8305

800-362-0706