



# PNEUVAC DRUM PUMP

## COMPRESSED AIR POWERED

**Designed to remove liquids, sludge and chips from:**

- Molding Machines
- Lathes
- Milling Machines
- Machining Centers
- Grinders
- Screw Machines
- EDM Machines
- Coolant Sumps
- Open Pits
- Tanks
- Spills

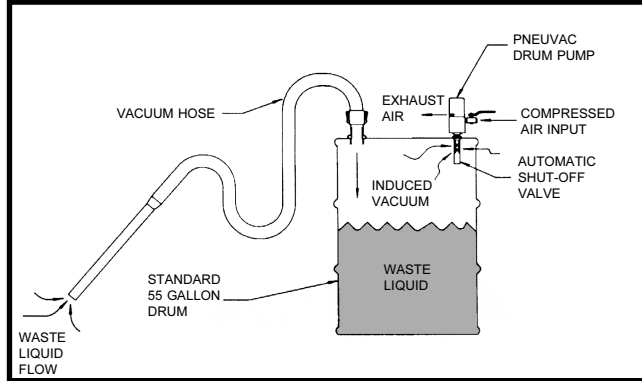

**Construction** - Entire pump (except ball valve, float and O-ring), is made from either stainless steel or aluminum. Some competitors' models are made from rust-prone carbon steels and light-duty plastics.

**Easy to Clean** - The pump can be completely disassembled for easy cleaning. Other models are welded together, requiring you to buy a new pump when it becomes clogged.

**Safety** - The PneuVac Drum Pump is powered by compressed air. This eliminates the possibility of electric shocks often associated with motor-driven pumps. The pump is also equipped with an automatic shut-off valve which activates when the drum is full.

**Speed** - The PneuVac Drum Pump can fill a 55-gallon drum in just 90 seconds. Conventional pumps can take up to one hour to move the same amount of liquid.

**Thoroughness** - This pump not only removes liquid but will also pick up sludge, metal chips and other debris which often clog or wear out impeller type pumps. Additionally, the pump will not lose its prime as the liquid level drops, eliminating the need to manually bail out the bottom of a sump.

**Quiet** - Unique baffle system limits noise level without compromising performance. Noise levels produced at 100 PSI are within OSHA regulations.

**Reliability** - Since there are no moving parts in the PneuVac Drum Pump, there are no costly motors or pumps to wear out. The only maintenance required is an occasional cleaning of the check valve to prevent sticking.

**Warranty** - This product carries a three-year Warranty against failure due to manufacturing defects. Similar units only carry a one-year warranty.

The PneuVac Drum Pump is a simple device that uses a compressed air powered Venturi to create a vacuum. All you have to do to operate the unit is: attach the pump and hose to a standard 55-gallon drum, hook up your compressed air supply to the pump, insert the free end of the suction hose into the sump or storage tank and open the air valve.



### PneuVac Drum Pump Kit

Consisting of pump, 1/4" ball valve, automatic shut-off valve, 10 ft. of smooth-bore hose, quick disconnect drum fittings, and one 18" aluminum wand.

**MODEL DP48010** Price **\$650.00** ea.  
(Stainless Steel Pump)

**MODEL DP48017** Price **\$550.00** ea.  
(Aluminum Pump)

### Performance Specification Chart

Pressure (PSI)	60	70	80	90	100
Air Consumption (CFM)	5.4	5.8	6.0	6.3	6.5
Vacuum (In Hg)	7.0	7.8	8.5	9.5	10.1
Noise Level (dB)	90	91	92	92	93
Water (Gals/Min)	35	39	42	44	46
Medium Weight Oil (Gals/min)	30	34	37	40	42

**CAUTION:** Do not use PneuVac Drum Pump with flammable or volatile liquids such as gasoline, alcohol, kerosene, aviation fuel, mineral spirits or any similar liquids with a low flash point. Air supply should be filtered and oil-free.



## PLASTIC PROCESS EQUIPMENT, INC.

www.ppe.com • e-mail: sales@ppe.com

**PPE WEST** 6385 Montessouri Street, Las Vegas, Nevada 89113  
702-433-6385 • 800-258-8877 • Fax: 702-433-6388

**PPE SOUTH** 11218 Challenger Avenue, Odessa, Florida 33556  
727-834-8888 • 800-282-6783 • Fax: 727-834-8873

8303 CORPORATE PARK DRIVE, MACEDONIA (Cleveland), OHIO 44056, USA

216-367-7000 • Toll Free: 800-321-0562 • Fax: 216-367-7022 • Order Fax: 800-223-8305

Toll Free: USA, Canada & Mexico  
**800-362-0706**