

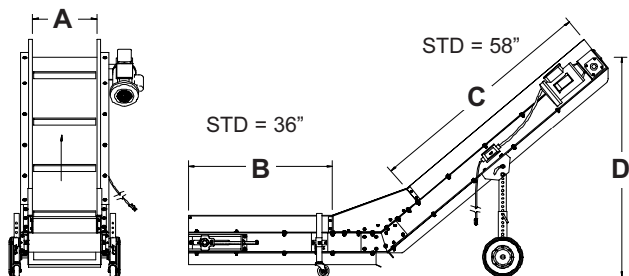

# CUSTOM CONVEYOR ORDER FORM

## HEAVY DUTY 40° FIXED INCLINE CONVEYORS

CONVEYOR STYLE:  
FIC



- A) Belt Width:  12"  18"  24"
- B) Infeed Length: \_\_\_\_\_
- C) Incline Length: \_\_\_\_\_
- D) Height to top of belt: \_\_\_\_\_
- E) Variable Speed Control:  Yes  No
- F) Control Options:
  - 1) On/Off controlled by electric eye. \$474.00
  - 2) On/Off Indexing on demand, electrical signal required.  
See Lenze Control System
  - 3) On/Off Indexing, Repeat Cycling. See BMT Feature
  - 4) E-Stop. \$156.00
- G) 4" high Side Rails:
  - 1) Mild Steel
  - 2) Stainless Steel
- H) Belt & Cleat options: White is standard
  - 1) Cleat height:  3/4"  1"  1-1/2"  2"
  - 2) Cleat spacing: \_\_\_\_\_
  - 3) Color: \_\_\_\_\_
  - 4) Specialty Belt: \_\_\_\_\_
- I) Other special features, specify:  
\_\_\_\_\_  
\_\_\_\_\_  
\_\_\_\_\_
- J) Export crating:  Yes  No

## VARIABLE INCLINE CONVEYORS

CONVEYOR STYLE:  
VIB  VIC  SIV

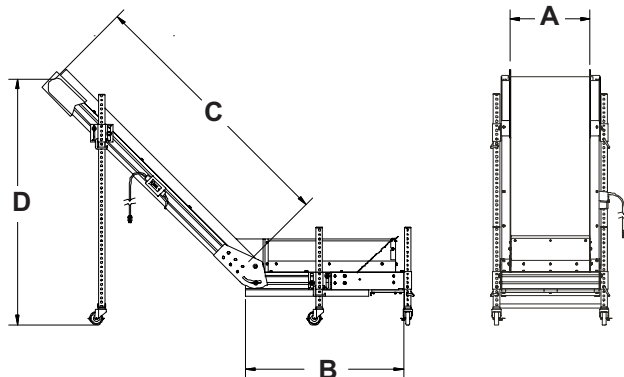

- A) Belt Width:  12"  18"  24"
- B) Infeed Length: \_\_\_\_\_
- C) Incline Length: \_\_\_\_\_
- D) Discharge height at 45°: \_\_\_\_\_
- E) Variable Speed Control:  Yes  No
- F) Control Options:
  - 1) On/Off controlled by electric eye. \$474.00
  - 2) On/Off Indexing on demand, electrical signal required.  
See Lenze Control System
  - 3) On/Off Indexing, Repeat Cycling. See BMT Feature
  - 4) E-Stop. \$156.00
- G) 3" high Side Rails:
  - 1) Anodized Aluminum
  - 2) Stainless Steel
- H) Belt & Cleat options: White is standard
  - 1) Cleat height:  3/4"  1"  1-1/2"
  - 2) Cleat spacing: \_\_\_\_\_
  - 3) Color: \_\_\_\_\_
  - 4) Specialty Belt: \_\_\_\_\_
- I) Other special features, specify:  
\_\_\_\_\_  
\_\_\_\_\_  
\_\_\_\_\_
- J) Export crating:  Yes  No

COMPANY NAME: \_\_\_\_\_

ADDRESS: \_\_\_\_\_

YOUR NAME: \_\_\_\_\_ / SIGNATURE: \_\_\_\_\_

TELEPHONE: (\_\_\_\_\_) - \_\_\_\_\_ - \_\_\_\_\_ FAX: (\_\_\_\_\_) - \_\_\_\_\_ - \_\_\_\_\_

E-MAIL: \_\_\_\_\_ PPE SALES PERSON: \_\_\_\_\_



## PLASTIC PROCESS EQUIPMENT, INC.

8303 CORPORATE PARK DRIVE  
MACEDONIA, OHIO 44056  
216-367-7000 • FAX: 216-367-7022  
TOLL FREE: 800-321-0562

6385 MONTESSOURI STREET  
LAS VEGAS, NEVADA 89113  
702-433-6385 • FAX: 702-433-6388  
TOLL FREE: 800-258-8877

www.ppe.com  
e-mail: sales@ppe.com

Toll Free: USA, Canada & Mexico  
**800-362-0706**

Order Fax: 800-223-8305