



CUSTOM CONVEYOR ORDER FORM

HORIZONTAL CONVEYORS

NON-CLEATED BELTS

CONVEYOR STYLE:

PC BCP FT

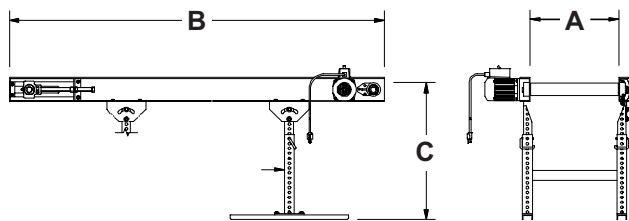

- A) Belt Width: 6" 12" 18" 24" 36" 48"
- B) Conveyor Length: _____
- C) Height to top of belt: _____
- D) Number of stands: _____
 1) Casters: Yes No
- E) Variable Speed Control: Yes No
- F) Control Options:
 1) On/Off controlled by electric eye. \$474.00
 2) On/Off Indexing on demand, electrical signal required.
 See Lenze Control System
 3) On/Off Indexing, Repeat Cycling. See BMT Feature
 4) Reverse on demand.
 See Lenze Control System
 5) E-Stop. \$156.00
- G) Motor mounted under conveyor: Yes No (*non-standard*) \$210.00
 See MU Feature
- H) Side Rails:
 1) 3" Anodized Aluminum
 2) 3" Stainless Steel
 3) 3-1/2" Mild Steel (*not available on FT Style*)
 4) 3-1/2" Stainless Steel (*not available on FT Style*)
 5) 4" Anodized Aluminum
 6) 4" Mild Steel
 7) 4" Stainless Steel
 8) 5" Mild Steel
 9) 5" Stainless Steel
- I) Belt & Cleat options: White is standard
 1) Cleat height: 3/4" 1" 1-1/2" 2"
 2) Cleat spacing: _____
 3) Color: _____
 4) Specialty Belt: _____
- J) Other special features, specify:

- K) Export crating: Yes No

INCLINE CONVEYORS

CLEATED BELTS

CONVEYOR STYLE:

SI BIC PCI VICB SCI

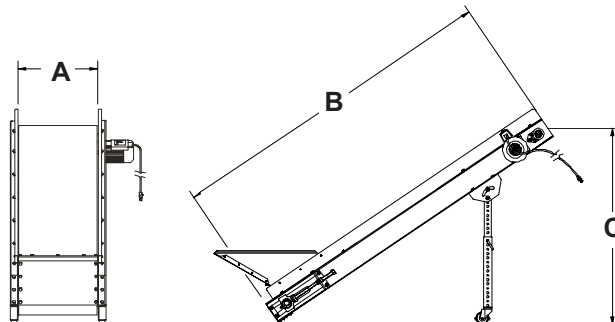

- A) Belt Width: 6" 8" 12" 18" 24"
- B) Conveyor Length: _____
- C) Drop height @ 45°: _____
- D) Variable Speed Control: Yes No
- E) Control Options:
 1) On/Off controlled by electric eye. \$474.00
 2) On/Off Indexing on demand, electrical signal required.
 See Lenze Control System
 3) On/Off Indexing, Repeat Cycling. See BMT Feature
 4) E-Stop. \$156.00
- F) Motor mounted under conveyor: Yes No (*non-standard*) \$210.00
 See MU Feature
- G) Side Rails:
 1) 3" Anodized Aluminum
 2) 3" Stainless Steel
 3) 4" Anodized Aluminum
 4) 4" Mild Steel
 5) 4" Stainless Steel
 6) 5" Mild Steel
 7) 5" Stainless Steel
- H) Belt & Cleat options: White is standard
 1) Cleat height: 3/4" 1" 1-1/2" 2"
 2) Cleat spacing: _____
 3) Color: _____
 4) Specialty Belt: _____
- I) Other special features, specify:

- J) Export crating: Yes No

COMPANY NAME: _____

ADDRESS: _____

YOUR NAME: _____ / SIGNATURE: _____

TELEPHONE: (_____) - _____ - _____ FAX: (_____) - _____ - _____

E-MAIL: _____ PPE SALES PERSON: _____



PLASTIC PROCESS EQUIPMENT, INC.

8303 CORPORATE PARK DRIVE
MACEDONIA, OHIO 44056
216-367-7000 • FAX: 216-367-7022
TOLL FREE: 800-321-0562

6385 MONTESSOURI STREET
LAS VEGAS, NEVADA 89113
702-433-6385 • FAX: 702-433-6388
TOLL FREE: 800-258-8877

www.ppe.com
e-mail: sales@ppe.com

Toll Free: USA, Canada & Mexico
800-362-0706

Order Fax: 800-223-8305