



PARTS SEPARATOR

FREE STANDING - 3 WIDTHS

FEATURES

- Solid 1/4" x 6" flat aluminum side plates with welded aluminum crossbraces (not bolted).
- Separator pins are 2-3/4" tall.
- Separator pin holes are 1/2" spaced center on center.
- Adjustable height.
- Separator can angle 360°.
- Portable—easy to move.
- Sprocket to roller drive totally enclosed for operator safety.
- Self-aligning bearings with take-up screws.



SPECIFICATIONS

- Belt is a heavy 2 ply white belt with FDA/USDA approval and stainless steel lacing.
- Belt speed 17-1/2 ft. per min.
- 1/15 H.P. 115/60/1 motor.
- 12' grounded power cord.
- Overload protected starter with pilot light.
- 2-3/4" from the top of the belt to the top of frame.

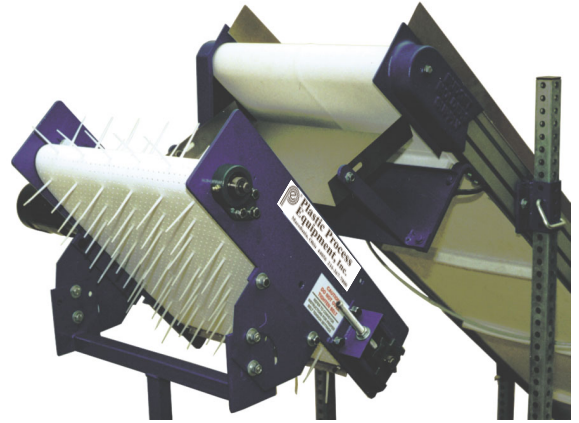

- SEPARATORS -

MODEL NO.	BELT WIDTH	*SEPARATOR PINS	PRICE
PSB-12	12"	200 included	\$2,013.00
PSB-18	18"	300 included	\$2,102.00
PSB-24	24"	400 included	\$2,158.00

*Pins not installed.

- SPARE PARTS -

PART NO.	DESCRIPTION	PRICE
1080*	Spare separator pins (100 per pack)	\$25.45
SBPSB-12	Spare belt for model #PSB-12 (no pins)	\$109.90
SBPSB-18	Spare belt for model #PSB-18 (no pins)	\$145.80
SBPSB-24	Spare belt for model #PSB-24 (no pins)	\$194.40

*Pins not included with spare belts.

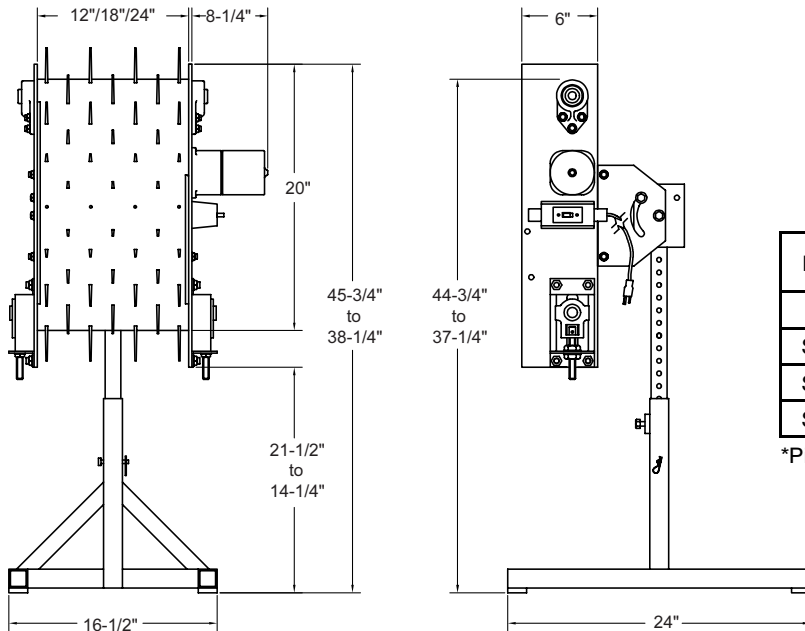

PLASTIC PROCESS EQUIPMENT, INC.

EAST 8303 CORPORATE PARK DRIVE
MACEDONIA, OHIO 44056-2300
216-367-7000 • FAX: 216-367-7022
TOLL FREE: 800-321-0562

WEST 6385 MONTESSOURI STREET
LAS VEGAS, NEVADA 89113-1186
702-433-6385 • FAX: 702-433-6388
TOLL FREE: 800-258-8877

www.ppe.com

e-mail: sales@ppe.com

Toll Free: USA, Canada & Mexico

800-362-0706

Order Fax: 800-223-8305