

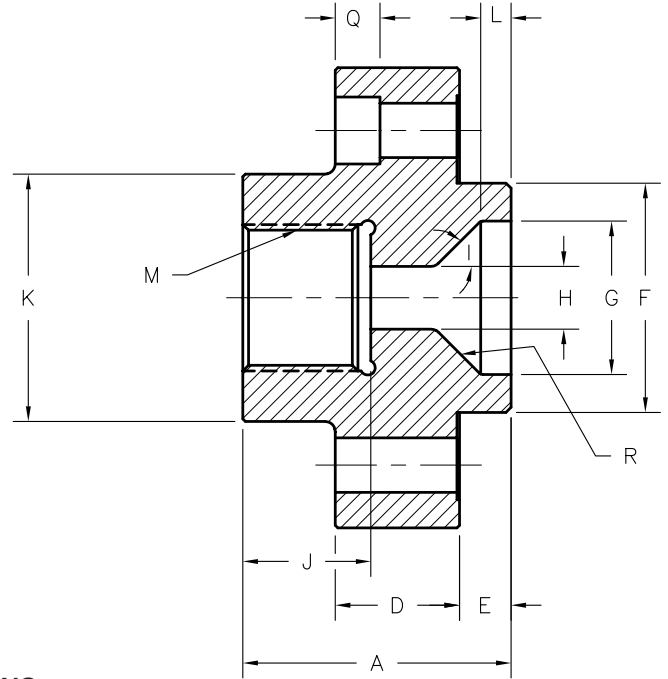

BARREL END CAPS AND ADAPTORS

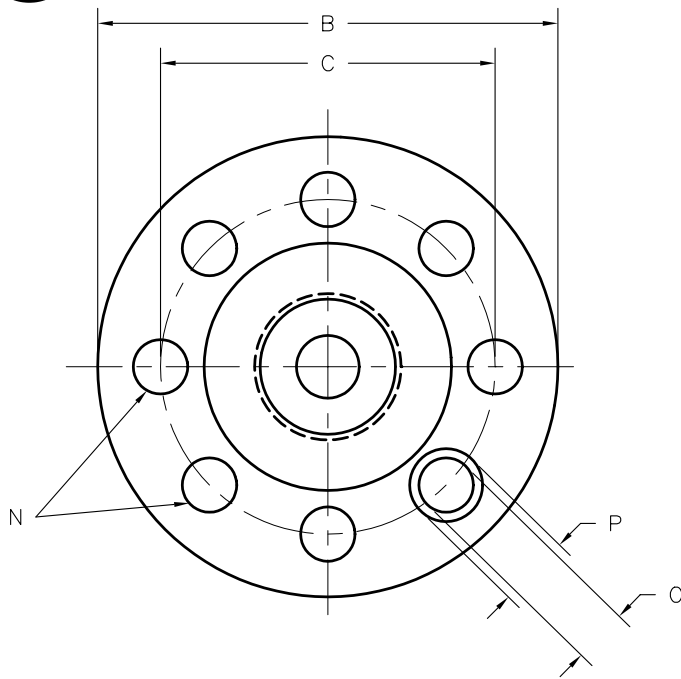

DIMENSIONS
Specify to 0.001 Inch

Machine Make	_____	J. Depth of Female Thread	_____
A. Overall Length	_____	K. Nozzle Support Diameter	_____
B. Flange Diameter	_____	L. Depth of Straight Bore	_____
C. Bolt Circle Diameter	_____	M. Thread Type	_____
D. Flange Width	_____	N. Number of Bolt Holes	_____
E. Length of Pilot	_____	O. Bolt Hole Diameter	_____
F. Pilot Diameter	_____	P. Counterbore Dia (if any)	_____
G. Rear Opening	_____	Q. Counterbore Depth (if any) ..	_____
H. Bore Diameter	_____	R. Surface Treatment	_____
I. Cone Angle	_____		

Indicate thermocouple hole position, depth and thread size.

**ANY MAKE OR MODEL
END CAP CAN BE MADE
TO YOUR SAMPLE OR DRAWING**

NORMALLY OUR END CAPS ARE MADE FROM NITRALLOY STEEL NITRIDE HARDENED, HOWEVER WE WILL MAKE THEM FROM 4140 HEAT TREATED OR WEAR RESISTANT D-2 STEEL HEAT TREATED. PLEASE SPECIFY!

© Copyright 2006 Plastic Process Equipment, Inc.
Note: PPE customers may reproduce this form only in it's entirety.



PLASTIC PROCESS EQUIPMENT, INC.

www.ppe.com • e-mail: sales@ppe.com

PPE WEST 6385 Montessouri Street, Las Vegas, Nevada 89113
702-433-6385 • 800-258-8877 • Fax: 702-433-6388

PPE SOUTH 11218 Challenger Avenue, Odessa, Florida 33556
727-834-8888 • 800-282-6783 • Fax: 727-834-8873

8303 CORPORATE PARK DRIVE, MACEDONIA (Cleveland), OHIO 44056, USA

Toll Free: USA, Canada & Mexico
800-362-0706

216-367-7000 • Toll Free: 800-321-0562 • Fax: 216-367-7022 • Order Fax: 800-223-8305