



SAFETY HOIST RINGS

SWIVELS 360° - PIVOTS 180°

MADE IN THE U.S.A.

-FEATURES-

- SAFE LIFTING AT ANY ANGLE.
- COMPENSATES FOR UNBALANCED LOADS.
- 5X SAFETY LOAD FACTOR.
- HEAT TREATED ALLOY STEEL.
- ALL COMPONENTS MAGNETIC PARTICLE INSPECTED 100%.
- SPARE BOLTS AVAILABLE.
- AMERICAN AND METRIC SIZES.

PERMITS YOU TO HANDLE MOLDS MORE SAFELY

ISO-9000

MANUFACTURED IN A QUALITY SYSTEM CERTIFIED FACILITY.



-SPECIFICATIONS-

- MATERIAL: AISI 4140 AIRCRAFT GRADE CHROME-MOLY HEAT TREATED MIL-H-6875
- 100% MAGNETIC PARTICLE INSPECTED IN ACCORDANCE WITH ASME SECTION 5 ARTICLE 1
- TESTED @ 5:1 STRENGTH FACTOR
- BLACK OXIDE COATED.
- SWIVELS 360° - PIVOTS 180°.
- MADE IN THE U.S.A.
- INSTALLATION INSTRUCTIONS INCLUDED WITH EACH HOIST RING.

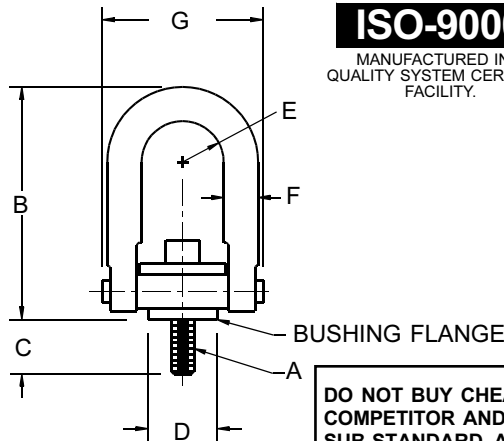

CAUTION

DO NOT BUY CHEAP IMITATIONS! WE BOUGHT ONE FROM A COMPETITOR AND FOUND THE DESIGN AND QUALITY TO BE SUB-STANDARD AND THEY WERE IMPORTED. THEY EVEN LOOKED UNSAFE. ALWAYS SPECIFY PPE HIGH QUALITY SAFETY HOIST RINGS! MADE IN THE U.S.A.

P.S. WE ALSO FOUND OUT THEIR PARTS WERE IMPORTED AND ASSEMBLED HERE IN THE U.S.A.. TO US IT MEANS IT'S STILL AN IMPORT!

SAFETY HOIST RING ASSEMBLIES (INCLUDES BOLT AND RETAINING RING)

A THREAD SIZE	LOAD CAPACITY LBS.	PART NUMBER	PRICES EACH	B	C THREAD LENGTH	E RADIUS	F DIA.	G WIDTH O.A.	TORQUE (LB.FT.)	WT. LBS.
5/16"-18	800	P23406	\$42.80	2.67	.54	.43	.375	1.84	7	.3
3/8"-16	1000	P23408	42.80	2.67	.54	.43	.38	1.84	12	.3
1/2"-13	2500	P23411	53.55	4.78	.78	.88	.75	3.52	28	2.5
5/8"-11	4000	P23414	53.55	4.78	1.03	.88	.75	3.52	60	2.5
3/4"-10	5000	P23417	53.55	4.78	1.03	.88	.75	3.52	100	2.7
7/8"-9	8000	P23423	117.70	6.52	1.04	1.40	1.00	5.14	160	6.8
1"-8	10,000	P23426	123.00	6.52	1.54	1.40	1.00	5.14	230	7.0
1 1/4"-7	15,000	P23429	208.65	8.73	1.89	1.75	1.25	6.50	470	14.5
1 3/8"-6	20,000	P23430	358.45	10.20	2.50	2.00	1.50	7.46	540	23
1 1/2"-6	24,000	P23433	256.80	12.47	2.70	2.25	1.75	8.55	800	33
2"-4 1/2	30,000	P23435	342.40	12.47	2.96	2.25	1.75	8.55	800	36
2 1/2"-8	50,000	P23439	1198.40	16.87	4.00	3.00	2.25	11.67	2100	88
2 1/2"-4	50,000	P23438	1198.40	16.87	4.00	3.00	2.25	11.67	2100	88
3"-4	75,000	P23440	2018.00	19.50	5.00	3.75	2.75	14.15	4300	166
3 1/2"-4	100,000	P23442	7008.50	22.09	7.00	4.00	3.25	15.90	5100	265

SPARE BOLTS W/RETAINING RINGS	
PART NO.	PRICE
P23606	\$3.60
P23608	3.60
P23611	6.25
P23614	7.30
P23617	9.20
P23623	14.45
P23626	16.55
P23629	51.00
P23630	62.00
P23633	85.85
P23635	136.60
P23639	213.00
P23638	193.10
P23640	QUOTE
N/A	N/A

METRIC HOIST RINGS

A THD. SIZE	LOAD CAP. (KG.)	PART NUMBER	PRICE	B (mm)	C (mm)	E (mm)	F (mm)	G (mm)	TORQUE (N-m)	WT. (LBS)
M8x1.25	400	P23456	\$59.45	68	13	11	10	47	9	0.4
M10x1.50	500	P23458	59.45	68	18	11	10	47	16	0.4
M12x1.75	1,050	P23462	73.80	121	19	22	19	89	37	2.5
M16x2.0	1,900	P23465	73.80	121	29	22	19	89	80	2.5
M20x2.5	2,150	P23468	77.00	121	34	22	19	89	135	2.7
M20x2.5	3,000	P23471	157.30	166	32	36	25	131	135	6.7
M24x3.0	4,200	P23474	157.30	166	37	36	25	131	311	7.0
M30x3.5	4,500	P23478	157.30	206	58	36	25	131	637	7.0
M30x3.5	7,000	P23479	288.90	222	67	45	32	165	637	15
M33x3.5	10,000	P23481	374.50	259	58	50	38	189	637	23
M36x4.0	11,000	P23483	337.00	317	68	57	44	217	1085	35
M42x4.5	12,500	P23484	363.80	317	83	57	44	217	1085	36
M48x5.0	13,500	P23485	390.55	317	83	57	44	217	1085	38
M64x6.0	22,300	P23488	1428.60	428	101	76	57	296	2847	86
M72x6.0	31,500	P23489	2381.00	495	132	95	70	359	5830	165
M80x6.0	31,500	P23490	2768.65	495	132	95	70	359	5830	165
M90x6.0	44,600	P23491	8472.00	561	177	102	83	404	6914	260
M100x6.0	44,600	P23492	8804.25	561	200	102	83	404	6914	280

PART NUMBER	PRICE
P23656	\$7.10
P23658	7.10
P23662	8.40
P23665	9.85
P23668	7.65
P23671	15.30
P23674	19.00
P23678	62.30
P23679	62.00
P23681	74.95
P23683	86.65
P23684	115.55
P23685	118.80
P23688	235.40
	N/A
	N/A
	N/A
	N/A

1. Stated load capacity based on specific thread torques as shown in chart.
2. It is recommended that these torques be used when installing hoist rings.



PLASTIC PROCESS EQUIPMENT, INC.

8303 CORPORATE PARK DRIVE, MACEDONIA (Cleveland), OHIO 44056, USA
216-367-7000 • Toll Free: 800-321-0562 • Fax: 216-367-7022 • Order Fax: 800-223-8305

www.ppe.com • e-mail: sales@ppe.com

Toll Free: USA, Canada & Mexico

800-362-0706

PPE WEST 3615 Walnut Avenue, Chino, California 91710, USA
909-627-8511 • 800-258-8877 • Fax: 909-627-8101

PPE SOUTH 11218 Challenger Avenue, Odessa, Florida 33556, USA
727-834-8888 • 800-282-6783 • Fax: 727-834-8873